

# SACKSAFOAM II MODEL 8044 MANUAL

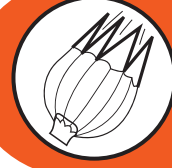

Bambi Bucket

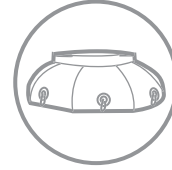

Fireflex

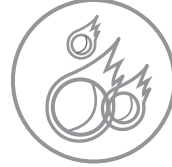

Dragon

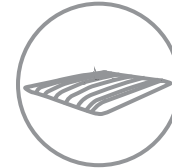

Remote Site

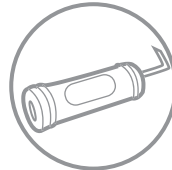

Environmental



Emergency Response



---

## **SACKSAFOAM II (MODEL 8044) MANUAL - Version C**

**Issue Date: October 2008**

**PLEASE READ BEFORE USING.**

### **SEI INDUSTRIES LTD.**

7400 Wilson Avenue  
Delta, B.C. Canada  
V4G 1E5

Phone: (604) 946-3131

Fax: (604) 940-9566

E-Mail: [seisales@sei-ind.com](mailto:seisales@sei-ind.com)

Website: [www.sei-ind.com](http://www.sei-ind.com)

COPYRIGHT © 2006 SEI INDUSTRIES LTD. ALL RIGHTS RESERVED  
PRINTED IN CANADA

---

# Table of Contents

|   |    |
|---|----|
| Section 1: Sacksafoam II Overview           | 1  |
| Introduction to Model 8044 .....            | 1  |
| System Description .....                    | 2  |
| <i>Unpacking</i> .....                      | 2  |
| Section 2: Installation                     | 3  |
| Installation Procedures .....               | 3  |
| Section 3: Testing                          | 7  |
| Testing the Sacksafoam .....                | 7  |
| <i>Dry Test</i> .....                       | 7  |
| <i>Wet Test</i> .....                       | 8  |
| Section 4: Safety                           | 9  |
| Preflight Safety Check .....                | 9  |
| Section 5: Controller Box                   | 10 |
| Control Box Description .....               | 10 |
| Controller Box Functions .....              | 11 |
| Controller Connector Pin Descriptions ..... | 12 |
| Section 6: Operations                       | 13 |
| Operating the System .....                  | 13 |
| <i>Container Size</i> .....                 | 14 |
| <i>Model SF2-8044 Run Times</i> .....       | 14 |
| Section 7: Maintenance                      | 15 |
| Maintenance and Servicing .....             | 15 |
| <i>Flushing Procedure</i> .....             | 15 |
| <i>Servicing</i> .....                      | 16 |
| Section 8: Parts                            | 17 |
| Parts and Diagrams .....                    | 17 |
| <i>Control Panel</i> .....                  | 17 |
| <i>Control Panel (Continued)</i> .....      | 18 |
| <i>Control Panel (Continued)</i> .....      | 19 |
| <i>Wiring Harness (Bambi)</i> .....         | 20 |
| Section 9: Warranty                         | 21 |

## Section 1: Sacksafoam II Overview

### Introduction to Model 8044

This manual provides helicopter operators with important information on the operation and maintenance of the Sacksafoam dispensing system for use with the Bambi bucket.

The Sacksafoam II has advanced features to enhance the efficiency of helicopter fire fighting.

The control box has a quartz digital timer to control the delivery of an accurate percentage of foam concentrate. The timer circuit has crowbar over-voltage protection and its own circuit breaker.

The operation of the Sacksafoam II can be quickly mastered by users with no prior experience. Several dumps with foam will provide familiarity with the use of the system.

Please read this manual prior to flying the bucket, particularly the sections on installation, filling and dispensing. If problems are experienced, please refer to the manual.

For your own protection and for longer system life, always heed the instructions and warnings. Ignoring them could result in damage to the Sacksafoam II, the Bambi bucket and aircraft or in personal injury.

SEI offers complete parts supply and repair facilities for the Sacksafoam II. For maintenance and repair purposes, parts diagrams and descriptions are provided in this manual.

When ordering parts, please provide the model and serial number of the unit which is printed on the back of the controller and on the inside of the container lid that is normally removed during operation. The side of the grey container also shows the Sacksafoam model number.

Additional copies of this manual are available from SEI Industries Ltd.



## System Description

The **Sacksafoam II Model SF2-8044** is used inside smaller helicopters to supply foam to the Bambi bucket (models 8096 to 1821).

Sacksafoam II model SF2-8044 will hold up to 10 USG (38 litres) of foam concentrate. The foam is held in two standard 5 USG (19 litre) containers within a large plastic case. The unit is self-contained and designed to prevent foam from contacting the helicopter.

The Sacksafoam pump is operated by a controller box with a long wiring harness. A timer on the controller box determines the amount of foam concentrate that is pumped into the Bambi bucket. This controller box comes in two models; an in-dash mount and a remote mounted model.

Ground crew members should replace the foam containers as required. In areas, where a second member is allowed on board, replacement of the container can be accomplished in flight. This same procedure applies to foam dispensing. Either the pilot or a crew member can activate the foam dispenser.

### Unpacking

Whether receiving the Sacksafoam II for the first time or unpacking it at the start of the season, ensure that you have the following:

1. Sacksafoam II unit
2. Controller box with cable
3. 6 ft. (1.8 m.) breakaway hose
4. 1 male/1 female garden hose fitting
5. Webbing tie-down straps (two), attached to the grey container.

The following operator-supplied equipment is also required:

1. Dump hose to supply foam to the Bambi bucket (5/8" hose with a 5/8" female garden hose fitting on one end).

#### Important Note

Cable and hose lengths must be determined by the operator. They will depend on the helicopter model, Bambi bucket model and length of the cargo line/longline in use. Please refer to the Bambi bucket operations manual.

## Section 2: Installation

### Installation Procedures

#### Installation of Wiring Harness



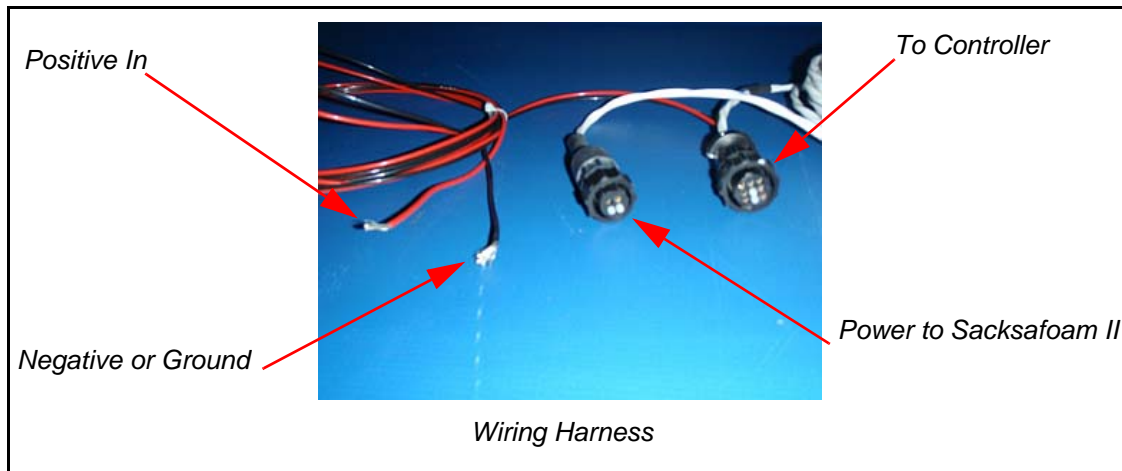

The control box has a 3-amp breaker that protects its electronic components. Be sure to observe the correct polarity. The control box will not operate if hooked up with reverse polarity.

The injection pump is protected by the helicopter circuit breaker. The injection pump will work, but at a greatly reduced volume, if hooked up with reverse polarity.

1. Connect power input wires (red is positive, black is negative) to a 28-volt direct current power supply, protected by a 10-amp breaker (20-amp breaker for HL series Sacksafoam only). In this case, 28-volts is the nominal charging voltage on a 24-volt system.

#### Important Note

Make sure the circuit can carry a load of 11-amps at 24VDC.

2. Depending on the model, mount the control box in the appropriate location (the standard model can be mounted in a convenient location, the console model must be mounted on the console).
3. Connect the nine-pin plug to the socket on the back of the control box (pin 1 is positive, pin 2 is negative).

#### Caution

Excessive force or twisting on the wiring connector can damage the contacts.

4. Place the Sacksafoam unit inside the helicopter and remove the lid. Ensure that the lid is stored securely or removed completely from the helicopter.

- 5. Secure the "D" rings to the cargo tie-downs on the floor of the helicopter. Tie the supplied webbing straps onto the Sacksafoam cleats.



- 6. Attach power to the unit.

- 7. Uncoil the stored breakaway hose and connect the breakaway hose to the foam outlet fitting.



- 8. Push the garden hose fitting into the free end of the breakaway hose.





**Warning**

Do not secure the garden hose fitting to the breakaway hose with a clamp. The breakaway hose is intended for safe jettisoning of the Bambi bucket.

9. Secure the breakaway hose to the helicopter. Run the 5/8" (16 mm) ID female garden hose from the end of the breakaway hose down to the Bambi bucket. Attach the hose to the suspension lines using tie wraps. Take care not to pinch or kink the hose as this will restrict the flow of foam.

**Important Note**

If the bucket has to be jettisoned, the hose will pull apart at the unclamped fitting. Since the breakaway hose is secured, there will be no tendency for the garden hose to pull the Sacksafoam from the helicopter. In this event, any foam in the hose will drip safely outside the helicopter.

## Section 3: Testing

### Testing the Sacksafoam

#### Important Note

The testing procedure should be performed before every use to check the operation of the Sacksafoam unit.

#### Dry Test

#### Important Note

A dry test can be done to determine if all power hook-ups are correct. Set the controller to 10 seconds, take one dip tube out and lift the float on the end of the dip tube. If the pump starts, the hook-up is correct.

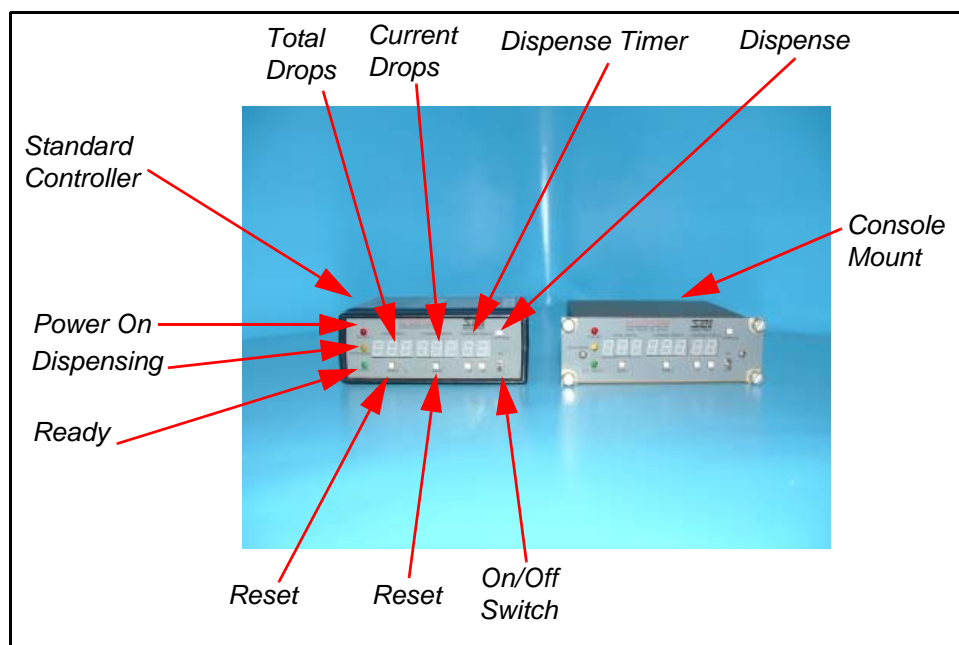

**Wet Test**

1. For the wet test, foam or water can be used for test purposes.
2. Place a full 5 USG container of fire-retardant foam in the space provided within the Sacksafoam case.
3. Insert the dip tube into the foam container and press the rubber stopper down to seal the filler neck. Push the dip tube down to contact the bottom of the container.



4. If you are using foam for the test, place a break away hose into the empty container.
5. Turn the controller on and set the dispense time to 10.
6. Activate the dispense switch.
7. The pump should now start. There may be a short delay until the pump primes itself. To complete the test, activate the dispense switch a second time. Foam or water should flow for 10 seconds.
8. Once the test is finished, store the dip tube as shown in the photo.

**Important Note**

Please see *Section 8: Parts* for the parts list to aid in identifying components.

## Section 4: Safety

### Preflight Safety Check

The Bambi bucket and Sacksafoam II system should receive a preflight inspection in the same manner as a pilot preflights the aircraft before use. To preflight the system, start at the bottom and work up.

1. Is the unit plugged into the helicopter's power source?
2. Is the controller secured inside the cockpit and plugged into the electrical box in the unit?
3. Are all wires in the helicopter secured to avoid tripping and tangling?
4. Is the Sacksafoam case secured with the tie down strap?
5. Is the breakaway hose secured to the Bambi bucket?
6. Is the pail of foam inside the Sacksafoam container?

Please refer to the Bambi bucket manual for the preflight check on the Bambi bucket itself.

## Section 5: Controller Box

### Control Box Description

The Sacksafoam controller box is the brains of the system and contains an accurate quartz digital timer to control delivery of foam concentrate to the Bambi bucket.



Since the Sacksafoam unit pumps foam at a fixed rate, the dispense time set on the controller relates directly to the foam concentration in the Bambi bucket. Circuit protection for the controller consists of a crowbar over-voltage protector and a 3-amp circuit breaker.



*The unit should look like this when ready to operate.*

## Controller Box Functions

| Item                  | Function   |
|-----------------------|--|
| On/off switch         | Toggle up to turn ON.<br>Toggle down to turn off and reset.  |
| Dispense switch       | Press/push button to begin dispensing foam.  |
| Dispense time switch  | Push buttons to set run time of foam injection pump.   |
| Current drops counter | Both counters increment every time dispense switch is pressed up (on). Current drops counter should be reset when Sacksafoam is refilled. Zero counter by pressing reset button.   |
| Total drops counter   | Both counters increment every time dispense switch is pressed up (on). Total drops counter can be used to count the total number of drops per day or shift. Zero counter by pressing reset button.                                       |
| Red power light       | Red light is on when power is on.  |
| Orange dispense light | Orange light is on when unit is dispensing foam.   |
| Green mix ready light | Green light is on when unit is ready for next dispense cycle or mixer (if installed) is running. The green light (and mixer; if installed) will go off when the Bambi bucket is dumped if green wire is hooked up to Bambi dump circuit. |

### Important Note

If the power supply polarity is reversed, the controller box will not operate. However, the Sacksafoam dispense pump will operate at a greatly reduced flow rate. If reverse polarity occurs, correct it immediately.

## Controller Connector Pin Descriptions

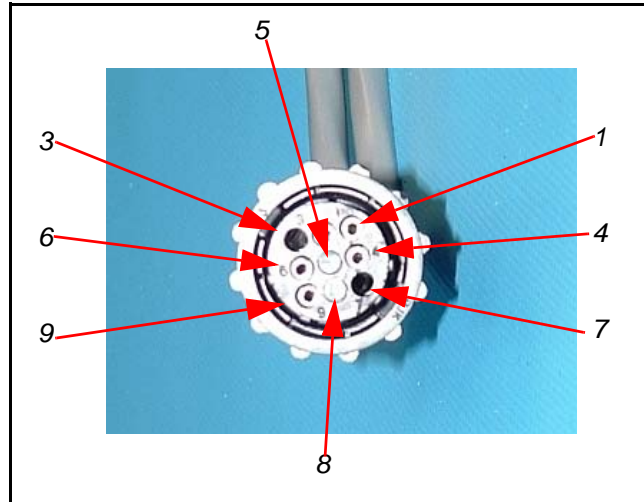

| Pin | Description                                  | Wire Color             |
|-----|--|------------------------|
| 1   | + 24 VDC supply                              | red                    |
| 2   | - 24 VDC supply                              | black                  |
| 3   | + 24 VDC to remote dispense switch (option)  | blue                   |
| 4   | +24 VDC to foam dispense pump                | white                  |
| 5   | plugged                                      |                        |
| 6   | - 24 VDC to foam dispense pump               | white with blue tracer |
| 7   | + 24 VDC 0.5 AMPS to mixer solenoid (option) | yellow                 |
| 8   | plugged                                      |                        |
| 9   | + 24 VDC from Bambi dump button              | green                  |

## Section 6: Operations

### Operating the System

Please perform the installation, testing and preflight inspection as previously described before operating the Sacksafoam II. This section should be read in conjunction with the Bambi bucket operations manual.

1. Place a full container of foam into one or both spaces of the Sacksafoam case.
2. Insert the dip tubes into the containers. Press in the rubber stoppers.
3. Refer to the *chart on the side of the Sacksafoam case* to set the controller box with the correct foam dispense time. The dispense time will vary with the size of the Bambi bucket you are using and the desired foam concentration.

#### Important Note

If you have an existing controller box with a black plastic case, disregard the dispense time chart on the top. It applies only to original Sacksafoam I units.

4. After the Bambi bucket has been filled with water, operate the controller box dispense switch to pump foam down to the bucket.
5. There are two red lights on the Sacksafoam control box, which, when lit, indicate that a foam container is empty. Replace the corresponding foam container with a full one. If you are unsure which container is empty, this can be determined by pulling the dip tube towards the top of the pail. If the other light does not come on, you have the right container.
6. While changing the foam containers, the dip tube can be stored in the black storage tube.

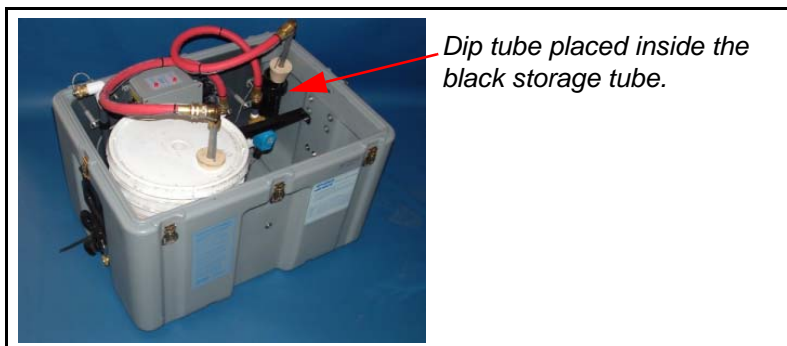



**Container Size**

The Sacksafoam container is 27" x 20" x 21 1/4" or 590 mm x 510 mm x 540 mm.

**Model SF2-8044 Specifications**

| SF II      | Bambi Bucket Model | Foam Concentrate Capacity |          |    | Empty and Full Weights |     |     |     |
|------------|--------------------|---------------------------|----------|----|------------------------|-----|-----|-----|
|            |                    | USG                       | Imp. Gal | L  | Lbs                    | Kgs | Lbs | Kgs |
| SF2 - 8044 | 6072 - 1821        | 10                        | 8        | 38 | 59                     | 27  | 67  | 30  |

**Model SF2-8044 Run Times**

Use the following chart to set the run time on the Sacksafoam container for the foam concentration required.

First, select your bucket size and concentration. The intersection of the row and column gives the run time in seconds. Set this time using the small push buttons on the front of the controller box.

**Caution**

Do not use the chart on the top of the controller box. Use the chart on the outside of the grey container or use the table below to determine run times.

| Bambi Model | Foam Concentration (%) |     |     |     |     |     |     |     |     |    |  |
|-------------|------------------------|-----|-----|-----|-----|-----|-----|-----|-----|----|--|
|             | 0.1                    | 0.2 | 0.3 | 0.4 | 0.5 | 0.6 | 0.7 | 0.8 | 0.9 | 1  |  |
| 8096        | 1                      | 2   | 4   | 5   | 6   | 7   | 9   | 10  | 11  | 12 |  |
| 9011        | 1                      | 3   | 4   | 6   | 7   | 8   | 10  | 11  | 13  | 14 |  |
| 1012        | 2                      | 3   | 5   | 6   | 8   | 9   | 11  | 12  | 14  | 16 |  |
| 1214        | 2                      | 4   | 6   | 7   | 9   | 11  | 13  | 15  | 17  | 19 |  |
| 1518        | 2                      | 5   | 7   | 9   | 12  | 14  | 16  | 19  | 21  | 23 |  |
| 1821        | 3                      | 6   | 8   | 11  | 14  | 17  | 20  | 22  | 25  | 28 |  |

## Section 7: Maintenance

### Maintenance and Servicing

The Sacksafoam II unit requires no maintenance other than cleaning. The unit should be flushed out with clean water daily, after use, and prior to storage.

#### Important Note

Proper cleaning of the equipment prior to storage will increase the life span of the unit.

#### *Flushing Procedure*

1. Insert one dip tube into a container of clean water.
2. Place the breakaway hose into a bucket and operate the Sacksafoam controller until the water runs clean.
3. Repeat step #2 for the other dip tube. Drain any remaining water from the piping and pump by alternately holding the dip tubes upside down and operating the Sacksafoam controller.
4. Foam or water in the Sacksafoam case can be drained by removing the drain cap and tipping the unit. Wipe out the case with a damp cloth.
5. Remove the drip tube to drain any residual foam.

#### Caution

Residual foam will form a waxy substance that can prevent proper operation of the Sacksafoam.

### Servicing

The gray plastic mounting panel carrying the pump, valves and electrical control box can be removed for servicing.

To remove the mounting panel:

1. Remove the three bolts holding the pail. Separate the interior frame.
2. Remove the three bolts holding the mounting panel.
3. Lift the assembly straight up with the wires attached. Lay the panel on top of the container.

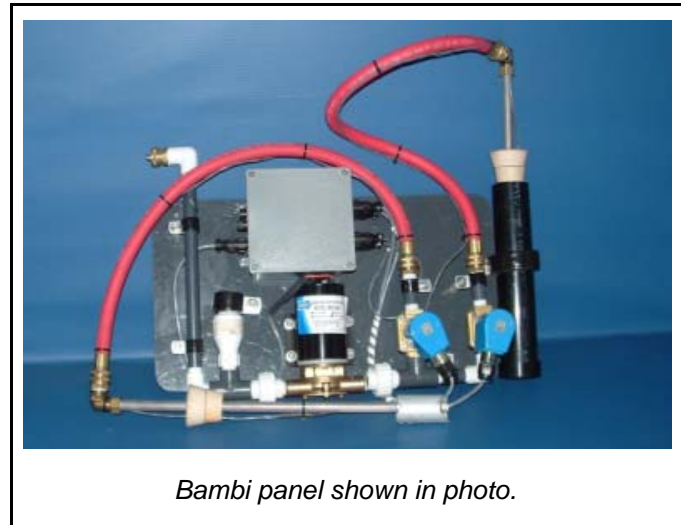

The pump impeller can be serviced without removing the pump from the mounting panel. Remove the four brass screws on the bottom of the pump to access the impeller. A spare impeller and seal are supplied with each Sacksafoam II unit.

If a solenoid valve does not operate properly, remove the blue coil by pulling off the securing clips (do not lose the wave washer installed under the coil).

Undo the four bolts and gently remove the top of the valve from the diaphragm. Clean the inside of the valve and the diaphragm using mild soap and water (do not lose the small spring that fits inside the metal stem attached to the diaphragm).

Test the unit after any servicing.

# Section 8: Parts

## Parts and Diagrams

### Control Panel

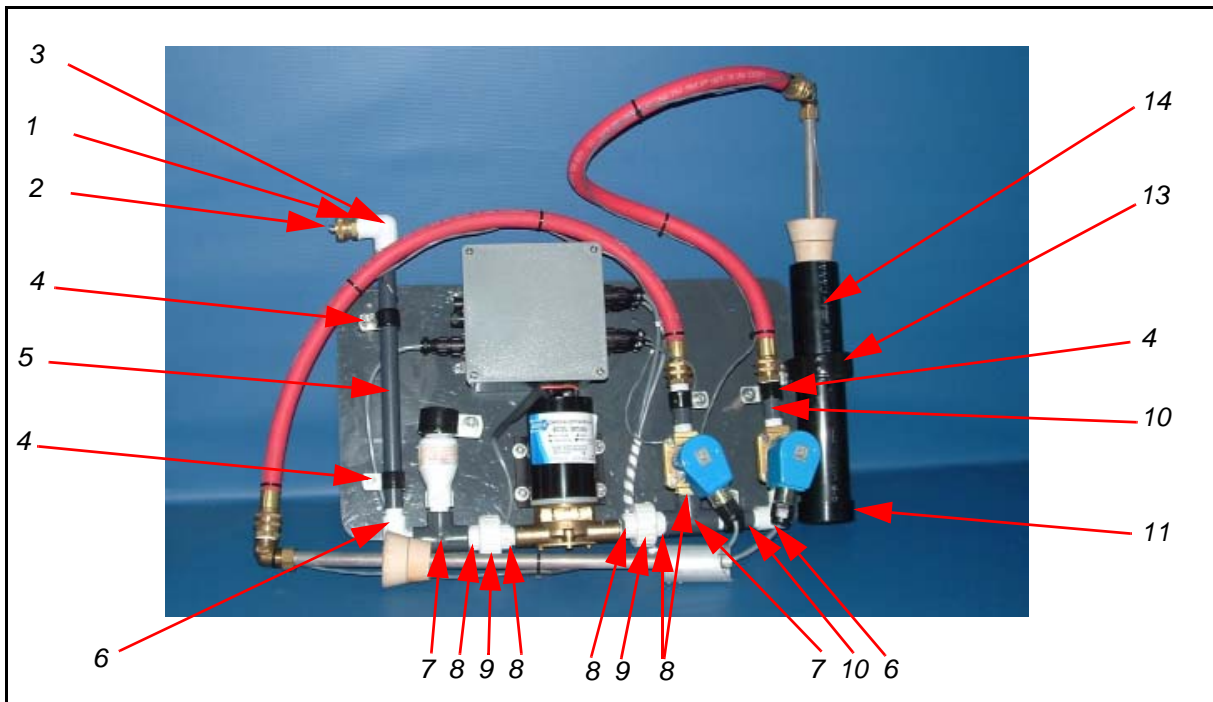

| ITEM # | PART #   | DESCRIPTION                                      | QTY. |
|--------|----------|--|------|
| 1      | PLB002   | ADAPTER BRASS MGHT X 1/2" MNPT                   | 1    |
| 2      | PLB000   | CAP BRASS FGHT                                   | 1    |
| 3      | PLP030   | ELBOW 90 deg. PVC SCH. 40 1/2" FPT               | 2    |
| 4      | PP613    | CLAMP SUPPORT 13/16 VINYL COATED                 | 4    |
| 5      | PLP00513 | NIPPLE PVC SCH. 80 1/2" MNPT 13"                 | 1    |
| 6      | PLP0205  | ELBOW STRET 90 deg. PVC SCH. 40 1/2" FNPT X MNPT | 1    |
| 7      | PLP1005  | TEE PVC SCH 80 FNPT                              | 2    |
| 8      | PLP005C  | NIPPLE PVC SCH 80 1/2" MNPT CLOSE                | 6    |
| 9      | PLP080   | UNION PVC SCH 40 1/2" FNPT                       | 2    |
| 10     | PLP053   | NIPPLE PVC SCH 80 1/2" MNPT 3' LONG              | 3    |
| 11     | PLP071   | PIPE CAP ABS 2" SLIP                             | 1    |
| 12     | PLB001   | ADAPTER BRASS MGHT X 1/2" FNPT                   | 2    |
| 13     | PP644    | CLAMP CABLE VINYL COATED 2 3/4"                  | 1    |
| 14     | PLP070   | PIPE ABS 2" X 12"                                | 1    |

**Control Panel (Continued)**

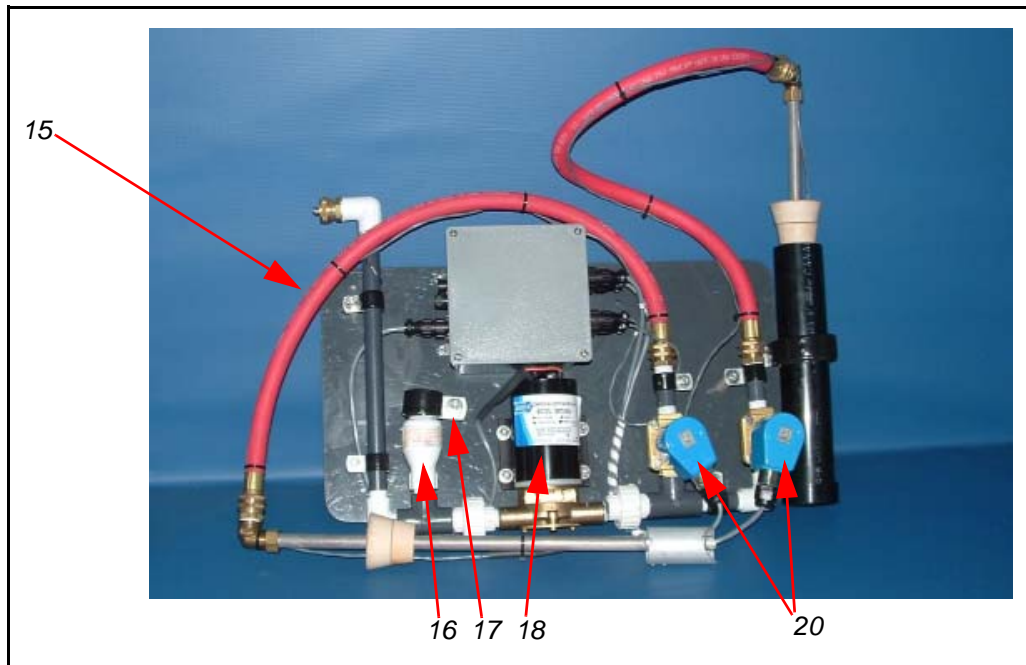

| ITEM # | PART #      | DESCRIPTION                        | QTY. |
|--------|-------------|------------------------------------|------|
| 15     | SFA006      | DIP TUBE ASSEMBLY C/W SWITCH       | 2    |
| 16     | PLV00305    | VALVE SPRING CHECK PVC 1/2" FNPT   | 1    |
| 17     | PP619       | SUPPORT CLAMP 1 3/16" VINYL COATED | 1    |
| 18     | SF3FILLPUMP | PUMP FILL JABSCO                   | 1    |
| 19     | SF3SENSOR   | SENSOR LEVEL SWITCH                | 1    |
| 20     | SF2VALVE    | SOLENOID VALVE 2 WAY 1/2" FNPT     | 2    |

Control Panel (Continued)

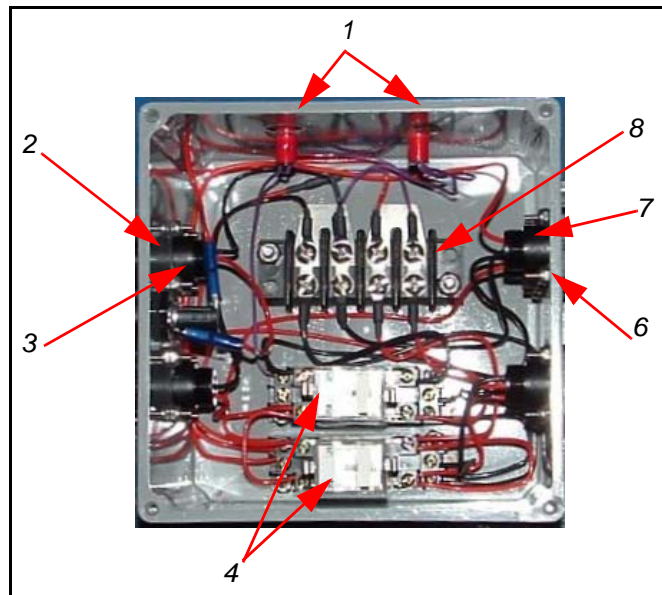

| ITEM # | PART #   | DESCRIPTION                     | QTY. |
|--------|----------|---------------------------------|------|
| 1      | ELAMP001 | RED GLO DOT PILOT LAMP          | 2    |
| 2      | EFUS003  | FUSE 1/4" X 1 1/4" GLASS 10 AMP | 1    |
| 3      | EFUS100  | FUSE HOLDER PANEL MOUNT         | 1    |
| 4      | EREL003  | RELAY DPDT 54 SWITCHING         | 2    |
| 5      | EREL004  | RELAY SOCKET                    | 2    |
| 6      | ECON021  | CONNECTOR PIN (See note below)  | 12   |
| 7      | ECON032  | RECEPTACLE 4 PIN                | 6    |
| 8      | ETERM002 | TERMINAL STIP 4 CONTACT         | 1    |

Please note: A special amp tool is required to attach the pins to the wires.

Wiring Diagram

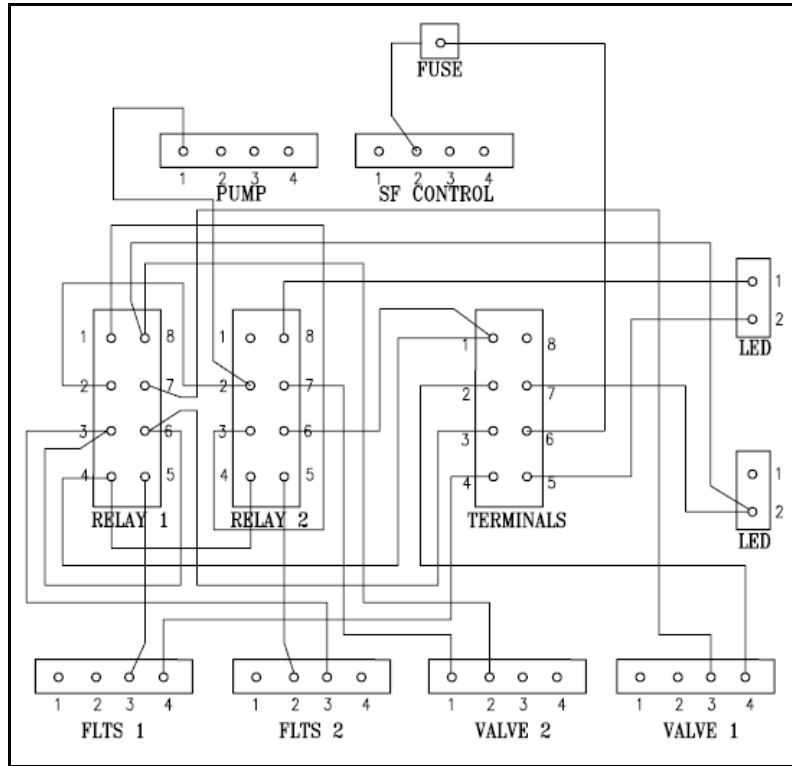

# Section 9: Warranty

- a) Warranty is limited to repairing or replacing, at the company's sole discretion, any product approved to be defective.
- b) The company's products are not guaranteed for any specific length of time or measure of service, but are warranted only to be free from defects in workmanship and material for a period of one year to the original purchaser.
- c) To the extent allowable under applicable law, the company's liability for consequential, incidental and environmental damages is expressly disclaimed. **The company's liability in all events is limited to and shall not exceed, the purchase price paid.**
- d) This warranty is granted to the original purchaser and does not extend to a subsequent purchaser or assignee.
- e) The company must receive notification in writing of any claims of warranty from the original purchaser which must give details of the claimed defect in the product.
- f) Where the original purchaser is claiming under warranty, the product must be returned to the company for inspection with all transportation and duty charges prepaid.
- g) The warranty does not extend to any product that has been accidentally damaged, abraded, altered, punctured, abused, misused or used for a purpose which has not been approved by the company.
- h) This warranty does not apply to any accessories used with the product such as pumps, filters, hoses, etc., that are not supplied by the company, and any warranty on such accessories must be requested from the manufacturer or dealer of the accessories.
- i) In the event the original purchaser does not give notice of a warranty claim within one year of the original purchase of the product, it is understood that the purchaser has waived the claim for warranty and the purchaser and/or any subsequent purchaser must accept the condition of the product as it may be, without warranty.
- j) Any technical information supplied by the company regarding the product is not a condition of warranty but rather is information provided by the company to the best of its knowledge.
- k) There are no implied warranties nor is there any warranty that can be assumed from any representation of any person, except the company itself.

### Exclusions

This warranty is void if the product is not assembled, used and/or maintained in accordance with the operator's manual supplied by SEI.