

# FOLDING INSTRUCTIONS FIREFLEX WATER RESERVOIRS/TANKS

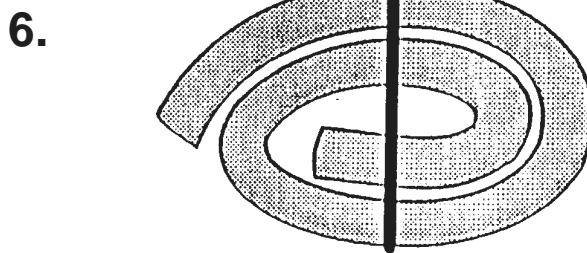
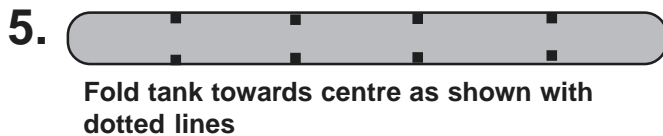
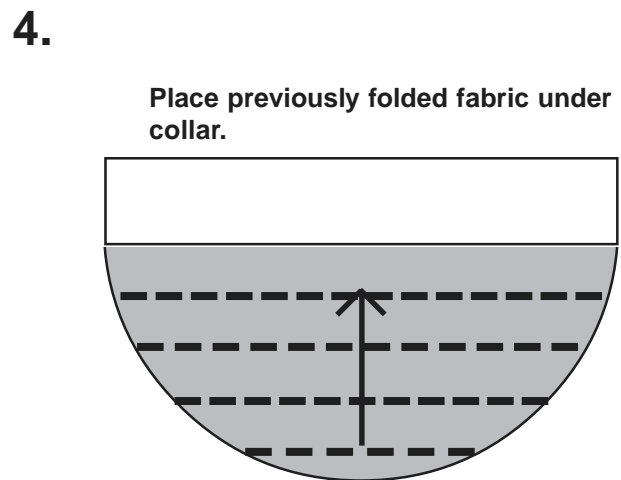
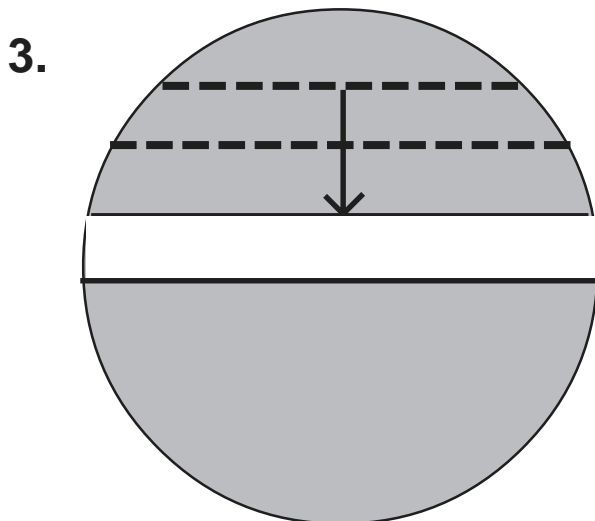
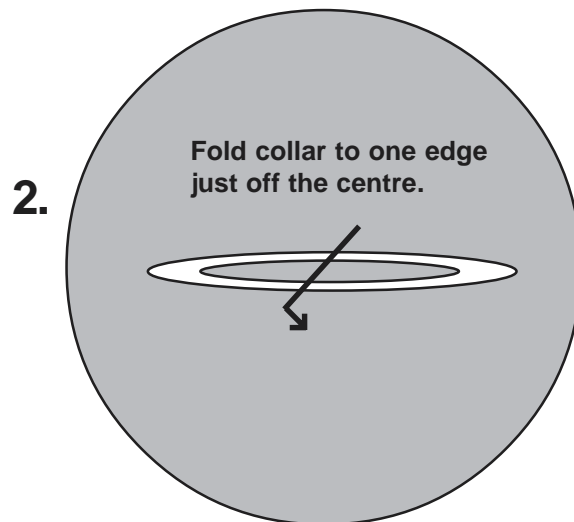
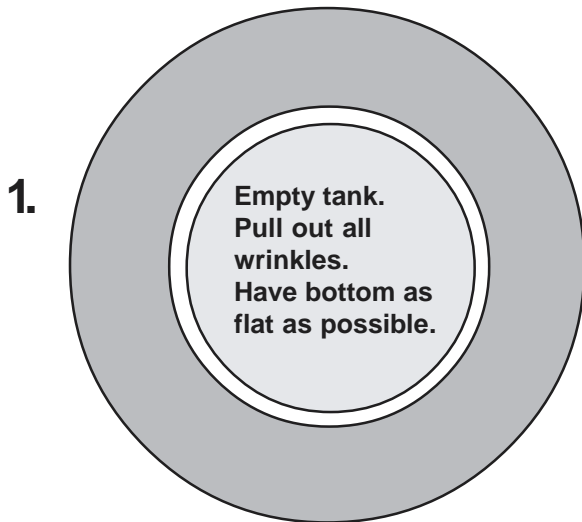

# OPERATING PROCEDURES FIREFLEX OPEN TOP TANKS

## SETTING UP THE TANK

- A. Place tank at back of tanker
- B. Unroll tank and spread on the ground pulling fabric folds on tank bottom flat.
- C. Pull out any wrinkles in bottom to achieve maximum volume.
- D. Place the edge of the tank either up to tanker tailgate or 3" - 6" under tailgate.

## FILLING THE TANK

- A. EITHER: Dump the first 100 gallons in slowly (10 - 15 seconds) then open up the valve fully.  
OR: tie one of the body "D" rings to the tailgate, open up the valve.
- B. Once you have the tank slightly filled, it will stabilize.
- C. The tank will rise on its own and when full, the tank will be 36" high. The distance from the outside diameter to the inside of the collar will be 24" maximum. this will allow the tanker easy discharge into the tank.
- D. The tank will be full when the water reaches the bottom of the collar and the sides are tight. If filling continues to the collar top, water will leak through the collar "D" rings.

## DRAFTING

- A. If you are using a 4" hard suction hose the collar will support it.
- B. If you are using a 5", 6" or 8" hard suction hose you may want to provide some support unless the hard suction is coming from a pump on a truck which is elevated approx. 30" - 36" from the ground.
- C. Maximizing water usage is accomplished by using a low level strainer on the suction hose.
- D. The 3" iron pipe flanges in the side of the tank are for drains. If you require special flanges for filling/discharging; we will be pleased to supply some at additional cost. ie. Storz, N.S.T. etc.

## DUMPING RESIDUAL WATER

- A. Open the 3" ports on the tank sides by removing the 3" plugs.
- B. When most of the water is drained put a rope through a "D" ring on the body of the tank at the top of the slope. Pull the tank over on top of its collar. Lift the sides to dump the residual water from the tank through the collar opening.

## FOLDING TANK

- A. Return tank to its normal position, pull folds out of bottom by pulling material flat.
- B. Next pull on collar "D" ring 180 degrees from each other so that both sides of collar lay on top of each other.
- C. The collar should be facing away from the direction from which you are folding. This allows entrapped air to escape.
- D. Start folding in 12" - 15" parallel folds from the edge of the tank towards the collar.
- E. When your folds are on top of the collar stop. Lift the collar, put the folds under the collar with the collar facing the opposite direction.
- F. Now fold the same as a "D" for the other half of the tank.
- G. The tank should now look like a long tube. About 2' from an end make your first fold. Roll the balance into a rolled tube, cinch the rolled tube across the width with the seat belt webbing strap provided.



Fireflex Division  
of SEI Industries Ltd.  
7400 Wilson Avenue  
Delta, B.C.  
Canada V4G 1H3  
Tel (604) 946-3131  
Fax (604) 940-9566