

Bambi
BUCKET®
Driven by Innovation



BUILT TO ENDURE

THE LEGENDARY BAMBI BUCKET

SEI Industries Ltd. introduced the original Bambi Bucket® to the firefighting community in 1982. This strong, but lightweight, flexible firefighting bucket, was the first, fully collapsible, aerial firefighting bucket.

Today, more than 35 years later, SEI services 95% of the world's aerial firefighting water bucket market.



Bambi Bucket Inventor Don Arney, during the early years of testing fabric strength.

BAMBI BUCKET: THE INDUSTRY STANDARD

Globally, the Bambi Bucket brand has become synonymous with aerial firefighting. The Bambi Bucket is now used in more than 115 countries around the world by more than 1,000 helicopter operators.



Key Benefits

- Cost-effective water delivery
- Easy to maintain
- Offers portable convenience

Key Features

- Fully collapsible
- High-flow dump valve
- Low power consumption (5A @ 28VDC)
- Designed for maximum durability and strength





The Bambi MAX Bucket offers the same robust, durable and dependable technology that you have come to know over the past 35+ years from the original Bambi Bucket®. Stay on fires longer with the Bambi MAX's added features.

The Bambi MAX Bucket offers 14 different sizes, ranging from 680 L (180 USG) to 9800 L (2590 USG).



Key Benefits

- Improve efficiency by splitting water load into multiple drops
- Improve efficiency by increasing bucket capacity through fuel cycle

Key Features

- Unlimited valve actuations
- Pilot-operated capacity control
- Low power consumption (5A @ 28VDC)
- Simple three-wire electrical connection



Also, the **Bambi MAX** comes with a 2-pump, or 4-pump (as shown in the photo on the right), internal configuration. This bottom-filling technology provides fill rates of 900 to 1,800 US gallons per minute. Retrofit kits available to convert your Bambi MAX to PowerFill Max.



SAFETY AND ACCURACY IN THE PALM OF YOUR HAND.

"With more than 8,000 hours and more than 25 wildfire seasons I consider the Bambi Max the best product for the fight against wildfires. In the process of innovation, Bambi Max provides safety and effectiveness when working on wildfires." **Francisco Lucas, Chief Pilot, Coyotair, Spain**



Contact one of our agents for more information...

**Toll Free:
1 866 570 FIRE (3473)**

POWERFILL SNORKEL

During fire season, many of the existing natural water sources such as rivers, creeks, stream beds or alpine meadows are too shallow to fully dip a bucket. The PowerFill Snorkel gives the ability to fill the bucket in shallow water sources including streams, ponds and low-profile dip tanks. It also provides additional functionality for load regulation and quicker dips.

PowerFill Snorkel provides hover filling capability in 18" (0.45 m) of water at a maximum rate of 450 USG/min (28 L/s). With its camlock connectors, the PowerFill Snorkel can be installed or removed in the field by one person in a matter of minutes.

Key Benefit

- Increases operational efficiencies by utilizing shallow water sources

Key Features

- Pump fills bucket at 450 USG/min (28 L/s) in only 18" (0.45 m) of water
- Conventional dipping method may still be used with the PowerFill Snorkel installed
- Installed or removed in the field by one person
- Retrofittable to most existing Bambi Buckets
- Requires 28VDC/45A power supply



POWERFILL MAX

PowerFill MAX allows partial or complete bucket fills from a range of previously inaccessible water sources as shallow as 18" (0.45 m), including streams, ponds and low-profile dip tanks. It is available for Bambi Max Bucket models BBX4453 – BBXHL9800.

PowerFill MAX is a two or four pump system mounted on the top plate of the Bambi MAX valve. When the bucket is immersed in water to the level of the top plate of the valve, the two electrically driven pumps can fill the bucket at 850 USG/min (54 L/s) – 1700 USG/min (106 L/s).

PowerFill MAX can be supplied as original equipment, or it can be added to an existing bucket.

Key Benefits

- Increases operational efficiencies by utilizing shallow water sources
- Faster fill times than PowerFill Snorkel

Key Features

- Pumps fill bucket at 850 USG/min (54 L/s) – 1700 USG/min (106 L/s) in only 18" (0.45 m) of water
- Conventional dipping method may still be used with the PowerFill MAX pumps installed
- Requires 28VDC/90A power supply

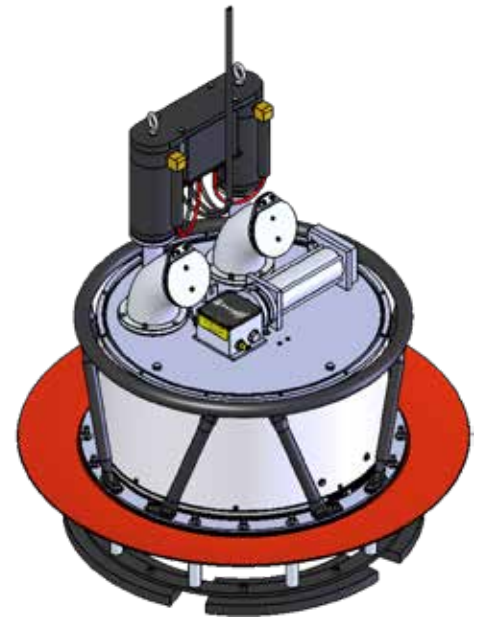

2-Pump Powerfill Max

CALL FOR INFO ON BAMBI LONGLINES AND OTHER PRODUCTS

North America:
1 866 570 FIRE (3473)

International:
1 866 43 BAMBI

Canadian Tel:
1 604 946 3131

E-mail: sales@sei-ind.com

Website: BambiBucket.com



Sacksafoam Heli-Case

The Sacksafoam™ Heli-Case is a foam-injection system designed for use with larger helicopters and flight crew. Storage for a 5 USG pale allows the large, built-in reservoir to be refilled on-the-fly with the dip tube and transfer pump. It is designed to be paired with a Sacksafoam Plus for more capacity.

The Sacksafoam™ Heli-Case can also supply power to, and control, a Standard Bambi or Bambi MAX Bucket.

With the Sacksafoam Controller, dispensing foam from the Heli-Case is easy and fully configurable for any bucket size.



Key Benefits

- Adds foam capability to bucketing operation
- Less time spent on the ground because the foam reservoir can be refilled on-the-fly
- Flight crew can operate the bucket and dispense foam allowing the pilot to focus on flying

Key Features

- Self-contained and designed to prevent foam from contacting the helicopter
- Transfer pump and dip tube allow the main reservoir to be refilled by 5 USG pales automatically
- Connections available to supply power to the bucket, and a hand control to operate the bucket and Heli-Case

Sacksafoam Bladder

The Sacksafoam™ Bladder is a foam-injection system designed for dispensing aerial firefighting foam. It is specifically designed to work in conjunction with the Bambi Bucket.

With the Sacksafoam Controller, dispensing foam from the bladder is easy and fully configurable for any bucket size.

Key Benefits

- Adds foam capability to bucketing operation

Key Features

- No foam concentrate in the aircraft
- Fast and easy installation
- Lightweight and collapsible



Sacksafoam Plus

The Sacksafoam Plus is a fully enclosed reserve tank for the Sacksafoam Heli-Case injection systems. It consists of two 20 gallon tanks allowing for more foam concentrate storage.

Designed for helicopters equipped with large Bambi Buckets (models BB5566 to BBHL9800), the Sacksafoam Plus helps maximize firefighting capabilities by synchronizing refueling and foam refill cycles.

Key Benefits

- Maximizes firefighting capabilities by synchronizing refueling and foam refill cycles

Key Features

- Tank holds 40 USG (150 L) of foam concentrate.
- Self-contained and designed to prevent foam from contacting the helicopter
- Robust construction, low maintenance.



Firesock

Attached to the bottom of a Bambi Bucket, the Firesock makes the bucket a more effective tool by providing dramatically improved coverage and suppression capabilities.

As water passes through the Firesock's mesh fabric, the Firesock breaks down water droplets, thereby increasing the exposed surface area making it ideal for combating certain types of blazes such as grass and brush fires.

When used with a Sacksafoam injection system, the Firesock increases the aeration of the foam and reduces foam concentrate usage by up to 50%.

Key Benefits

- Increases foam aeration
- Reduces the amount of foam concentrate used
- Provides 100% longer drop pattern

Key Features

- Clips to the bottom chain/cable of the Bambi Bucket
- Heavy duty industrial mesh fabric construction
- Can be easily cleaned, detached and stored for reuse



BAMBI POWERPACK™

The Bambi Power Pack is a portable, rechargeable power supply used to operate the Bambi Bucket or Bambi MAX Bucket independently of the helicopter's power supply.

It consists of a battery pack, battery charger, bucket wiring harness, aircraft grounding harness, and remote dump switch.

Based on a three-minute operational cycle, the power supply will operate the bucket for 10 hours of firefighting with a fully charged battery.

The charger plugs into a 110VAC/60Hz or 220VAC/50Hz power source, which fully recharges the battery pack in two hours.

Key Benefit

- Operate bucket independent of aircraft power

Key Features

- Compact and portable
- Up to 10 hours of operation / recharges in 2 hours
- Charger compatible with 110VAC/60Hz or 220VAC/50Hz power sources
- Grounding harness to prevent static charge buildup



MOBILITY SLED™

The mobility sled is a convenient allowing one person to load and unload even the largest Bambi Buckets.

The four-wheeled mobility sled comes equipped with 16" foam filled, all-terrain tires, tow bar and a braking system.

It can be quickly dismantled for shipping. Roll, winch and go.

A three-wheeled variant is also available.

Key Benefit

- One person can load and transport bucket

Key Features

- 4 x16" foam-filled, all-terrain tires
- Lockable front wheels
- Compatible with CH-47 cargo bay ramp



SPECIFICATIONS & COMPATIBILITY

	CAPACITY				EMPTY WEIGHT		GROSS WEIGHT		OVERALL LENGTH*		Firesock	Power Pack	PowerFill Snorkel	PowerFill Max	Sacksafoam Bladder	Sacksafoam Heili-Case	Sacksafoam Plus
	USG	liters	lbs	kg	lbs	kg	ft	m									
BAMBI BUCKET																	
BB6072	72	270	70	32	670	300	12'-11"	3.94		•							
BB8096	96	360	73	33	870	400	14'-6"	4.42		•							
BB9011	108	410	74	34	970	440	14'-6"	4.42	•	•							
BB1012	120	450	74	33	1 070	490	14'-6"	4.42	•	•							
BB1214	144	550	75	34	1 280	580	14'-10"	4.52	•	•							
BB1518	180	680	79	36	1 580	720	15'-2"	4.62	•	•							
BB1821	216	820	88	40	1 890	860	15'-11"	4.85	•	•	•						
BB2024	240	910	130	59	2 130	970	20'-1"	6.13	•	•	•						
BB2226	260	1 000	128	58	2 330	1 060	15'-10"	4.82	•	•	•						
BB2732	320	1 230	137	62	2 840	1 290	23'-0"	7.00	•	•	•						
BB3542	420	1 590	145	66	3 650	1 650	23'-8"	7.22	•	•	•						
BB4453	530	2 000	180	80	4 580	2 080	23'-9"	7.25	•	•	•						
BB5566	660	2 500	260	120	5 760	2 610	24'-0"	7.32	•	•	•						
BB680K	680	2 570	270	120	5 930	2 690	24'-0"	7.32	•	•							
BB6578	780	2 950	310	140	6 810	3 090	24'-2"	7.37	•	•							
BB7590	900	3 410	340	150	7 840	3 550	30'-3"	9.21	•	•							
BBHL4000	1 060	4 000	360	160	9 160	4 150	31'-8"	9.65	•	•							
BBHL5000	1 320	5 000	390	180	11 390	5 170	32'-0"	9.75	•	•							
BBHL7600	2 010	7 600	470	210	17 190	7 800	32'-5"	9.87	•	•							
BBHL9800	2 590	9 800	530	240	22 090	10 020	33'-6"	10.21	•	•							
BAMBI MAX																	
BBX1518	180	680	95	43	1 600	720	13'-3"	4.05	•	•							
BBX1821	216	820	105	48	1 900	860	13'-6"	4.10	•	•							
BBX2024	240	910	140	63	2 140	970	17'-8"	5.39	•	•							
BBX2226	260	1 000	138	63	2 340	1 060	13'-6"	4.11	•	•							
BBX2732	320	1 230	148	67	2 850	1 290	20'-7"	6.27	•	•							
BBX3542	420	1 590	155	70	3 660	1 660	21'-3"	6.48	•	•							
BBX4453	530	2 000	230	100	4 630	2 100	21'-3"	6.48	•	•							
BBX5566	660	2 500	300	140	5 800	2 630	21'-5"	6.53	•	•	•						
BBX6578	780	2 950	340	150	6 840	3 100	21'-8"	6.60	•	•	•						
BBX7590	900	3 410	370	170	7 870	3 570	27'-11"	8.51	•	•	•						
BBXHL4000	1 060	4 000	380	170	9 180	4 160	28'-11"	8.81	•	•	•						
BBXHL5000	1 320	5 000	400	180	11 400	5 170	29'-3"	8.92	•	•	•						
BBXHL7600	2 010	7 600	490	220	17 210	7 800	30'-4"	9.24	•	•							
BBXHL9800	2 590	9 800	550	250	22 110	10 030	31'-5"	9.58	•	•							

*Bambi BBT 4453 | 5566 | 6578 are discontinued.
Please contact SEI Industries for more information.

Specifications are subject to change without notice.
Weights listed above do not account for accessories.



SEI Industries Ltd.

7400 Wilson Avenue, Delta, British Columbia, Canada, V4G 1H3

International: 1 866 570 FIRE (3473), Canadian Tel: 1 604 946 3131, E-mail: sales@sei-ind.com

BambiBucket.com



DRIVEN BY INNOVATION



Bambi
BUCKET®

SEI Industries Ltd. • 7400 Wilson Avenue, Delta, British Columbia, Canada, V4G 1H3
Toll Free: 1 866 570 3473, T: 604 946 3131, F: 604 940 9566
sales@sei-ind.com • sei-ind.com