

# BATT<sup>®</sup>

BULK AVIATION TRANSPORT TANK  
patents pending



SEI's new bulk aviation transport tank is the world's first double-walled, baffled fuel transportation tank. Each tank is designed specifically for the aircraft using it to ensure a precise fit and to maximize the load-carrying capacity of the aircraft. Bulk fuel aviation transport tanks are made from two main components: a heavy duty, abrasion-resistant outer tank (with a built-in strapping system that also serves as secondary containment) and a fuel-specific, baffled inner tank.

## CIVILIAN MARKET

Few remote sites have year-round delivery from tanker trucks or barges so aircraft or helicopters are typically used to transport fuel supplies. Now, with the development of the BATT, remote site operators have an innovative new option that is both economical and efficient. Operators can fly fuel out, empty the BATT, roll it up and then head back with a full load of cargo or passengers.

## MILITARY MARKET

Military clients use remote fuel caches for emergency response, northern operations and the re-supply of forward operating areas that are cut off because ground transport is too risky or other access is unavailable. SEI's new bulk aviation transport tanks provide the perfect solution for these mission critical needs.

## BENEFITS

Bulk aviation transport tanks deliver several cost, safety and environmental benefits.

- **ECONOMIC:** Remote site operators can now purchase bulk fuel easily while also eliminating the cost of returning empty drums. Air operators can maximize load-carrying capacity on flights. Dead head flights with no cargo or passengers can be minimized because BATTs can be folded up and stored, when not in use.
- **SAFETY:** BATTs are designed to fit each specific aircraft which ensures that the payload doesn't shift (unlike drums which are not designed to fit or be secured inside an aircraft). The BATT's double-walled design, with built-in restraining straps and baffles, minimizes liquid dynamics. Each tank is designed with a 5:1 safety factor.
- **ENVIRONMENTAL:** BATTs allow remote site operators to eliminate the use of drums which are often abandoned, when empty, because of the high cost associated with removing them. Fuel spills associated with handling multiple drums are also eliminated.

## BATT™ (Bulk Aviation Transport Tank)

patents pending

### OUTER TANK

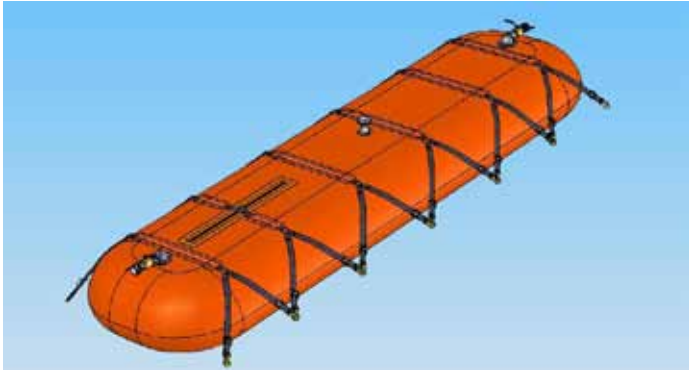

The BATT's complex buffering system is designed specifically for fluid travelling inside an aircraft.

### OUTER TANK

- The outer tank is resistant to abrasion and puncture and provides 100% secondary containment for the inner tank.
- The outer tank's strapping system enables it to be secured to the cargo deck with adjustable webbing straps.
- Each strap has an adjustable cam-buckle and a snap hook
- The strapping system is specific to each airframe and is connected to the tank by stainless-steel forged D-rings.
- All straps are made from heavy-duty, poly-webbing with a working load rating of 10,000 lbs / 4536 kg.
- Additional connecting links are provided to connect the tank to tie-down points in the cargo area.
- The outer tank has a leak-proof, chemical-resistant, liquid-tight zipper that can be opened to remove the inner tank for inspection and repair.

### TANK FITTINGS AND VENTS

- Flanges/connections on the inner tank meet or exceed MIL-T-52983G.
- The tank has a 1 ½" vent system for the container which can be connected to an external vent system in the cargo hold area. The vent is connected to a hose that is secured in the aircraft and exits outside the cargo area during filling.
- Tanks have two 2" top fill/discharge ports with ball valves and camlock connections as well as tethered dust plugs/caps.
- The tank has a 2" bottom drain fitting with a ball valve and can be connected to a pump that will off-load fuel at the site.
- A selection of plugs and clamps are included in a small emergency repair kit that is permanently attached to the tank and clearly marked. These plugs and clamps can be used to seal leaks while the tank is in-flight or on the ground.

### FIXED WING INNER TANK

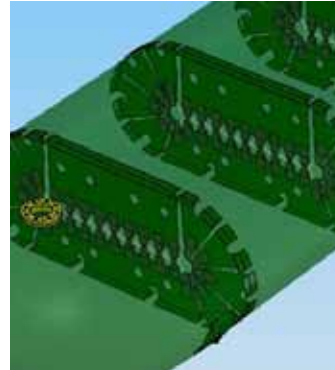

### ROTARY WING INNER TANK

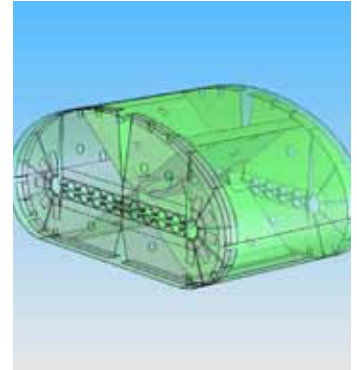

The BATT's revolutionary inner tank buffers vertical and horizontal movements.

### INNER TANK

- The inner tank has a unique curvilinear contour baffling or wave buffering system that matches with the natural shape of a filled tank.
- The fabric and the seaming of the inner tank meets or exceeds MIL-T-52983G.
- The inner tank has test strips that are removed and sent back to the manufacturer for review annually.

### MODELS

- The BATT comes in a range of sizes to fit various aircraft. Currently, the DC-3, MIL-17, Cessna Caravan and Twin Otter models are available. Future sizes include models for the DC-6, Sikorsky S-61, Bell 412 and C-130 Hercules aircraft.

### CERTIFICATION

In the past, only fuel drums were allowed to transport fuel without special permits. Today, SEI is proud to be the first company to receive a Transportation of Dangerous Goods Equivalency Certificate (SA 10638) from Transport Canada allowing the BATT to be used without special permits for the transportation of fuels.

This certificate states that the BATT is limited to supplying fuel to areas with remote access or where other transportation options are not readily available or practical. The certificate also states that the fuel must be loaded into a flexible tank that meets all the specifications of the BATT as manufactured by SEI Industries.