

SACKSAFOAM I MANUAL

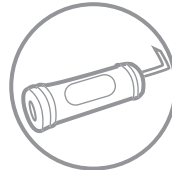
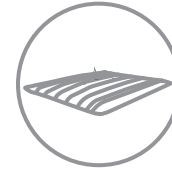
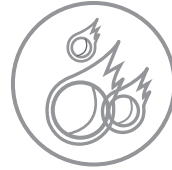
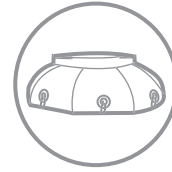
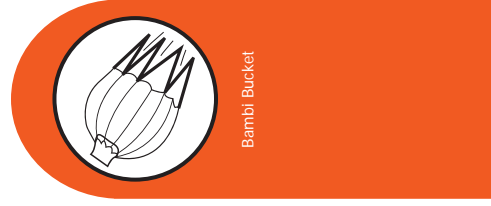

SACKSAFOAM I MANUAL - Version C

Issue Date: February 2008

PLEASE READ BEFORE USING.

SEI INDUSTRIES LTD.

7400 Wilson Avenue
Delta, B.C. Canada
V4G 1E5

Phone: (604) 946-3131

Fax: (604) 940-9566

E-Mail: seisales@sei-ind.com

Website: www.sei-ind.com

COPYRIGHT © 2006 SEI INDUSTRIES LTD. ALL RIGHTS RESERVED
PRINTED IN CANADA



Sacksafoam I Operations Manual (Version C)

Table of Contents

Section 1: Sacksafoam 1 Overview	1
Introduction	1
<i>Main Components</i>	2
Section 2: Sacksafoam Installation	3
Installation Instructions	3
Models 8018, 2044 and 5550	4
<i>Installation Procedure</i>	4
<i>Chain Length Specifications</i>	5
Model 7698	10
<i>Installation Procedure</i>	10
Section 3: Safety	12
Preflight Safety Check	12
Section 4: Control Box	13
Wiring the Control Box	13
<i>Using Long Lines</i>	14
<i>Wire Specifications</i>	14
Section 5: Operations	15
Operating All Models	15
<i>Filling the Sack</i>	15
<i>Dispensing Foam</i>	17
<i>Variation in Foam Viscosity</i>	18
<i>Using Non-Standard Voltages</i>	19
<i>Removing the Sack from the Bucket</i>	19
Section 6: Troubleshooting	21
Troubleshooting Chart	21
Section 7: Maintenance	22
Maintenance Procedures	22
<i>Flushing Procedure</i>	22
Section 8: Specifications	23
Sacksafoam Specifications	23
<i>Sacksafoam Models</i>	23
<i>Control Box Specifications</i>	23
<i>Control Box 9 Pin Connector Configuration</i>	24

Section 9: Sacksafoam Parts Lists	25
Models 8018, 2044 and 5550 2	25
<i>Internal Pump Assembly (Back Side)</i>	26
<i>External Parts</i>	27
<i>Complete Unit</i>	28
Model 7698 Parts List	29
<i>External Parts</i>	29
<i>Internal Pump Assembly</i>	30
<i>Fill and Discharge Flange Assembly</i>	31
 Section 10: Warranty	 32

Section 1: Sacksafoam 1 Overview

Introduction

This manual provides helicopter operators with important information on the operation and maintenance of the Sacksafoam I dispensing system for use with the Bambi bucket.

Please read this manual prior to flying the bucket, particularly the sections on installation, filling and dispensing. If problems are experienced, please refer to the manual. Section 6 *Troubleshooting* may be especially helpful.

For your own protection and for longer system life, always heed the instructions and warnings. Ignoring them could result in damage to the Sacksafoam I, Bambi bucket, aircraft or personal injury.

The Sacksafoam I has a number of advanced features to enhance the efficiency of helicopter fire fighting:

- The control box has a quartz digital timer to control delivery of an accurate percentage of foam concentrate. The timer circuit has crowbar over-voltage protection and its own circuit breaker. The system supports a mixer, if required.
- The sack containing the foam concentrate mounts in the Bambi bucket. This eliminates spillage and possible corrosion damage associated with carrying foam concentrate inside the helicopter. An internal check valve stops water from flowing into the sack and insures that foam is dispensed only while the injection pump is operating. Because the foam in the sack displaces the water in the Bambi bucket, the total payload is always constant.
- An optional foam transfer pump for easily filling the Sacksafoam I is available from SEI Industries. This portable pump greatly facilitates the filling of the Sacksafoam I and is powered by 24 volts DC, either from the aircraft or from an auxiliary power source.
- The operation of the Sacksafoam I can be quickly mastered by users with no prior experience. Several dumps with foam will provide familiarity with the use of the system.

SEI offers complete parts supply and repair facilities for the Sacksafoam I. For maintenance and repair purposes, parts diagrams and descriptions are provided in Section 9 *Parts*. When ordering parts, please provide the model and serial number of the sack (which are stamped into one of the fender washers at the bottom of the sack).

Additional copies of this manual are also available from SEI Industries Ltd.

Main Components

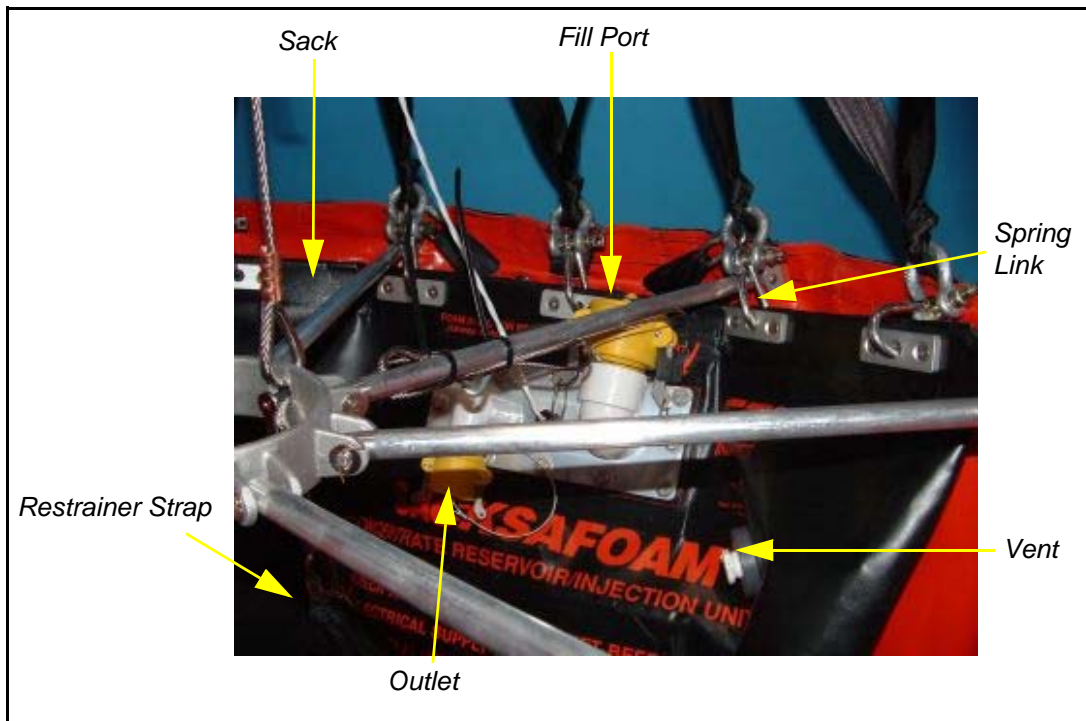
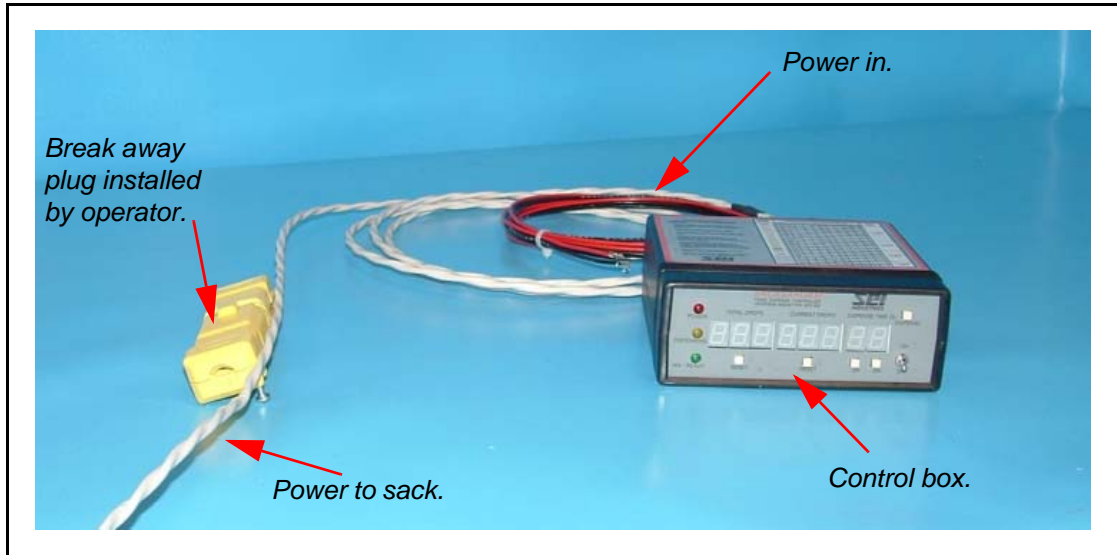

Section 2: Sacksafoam Installation

Installation Instructions

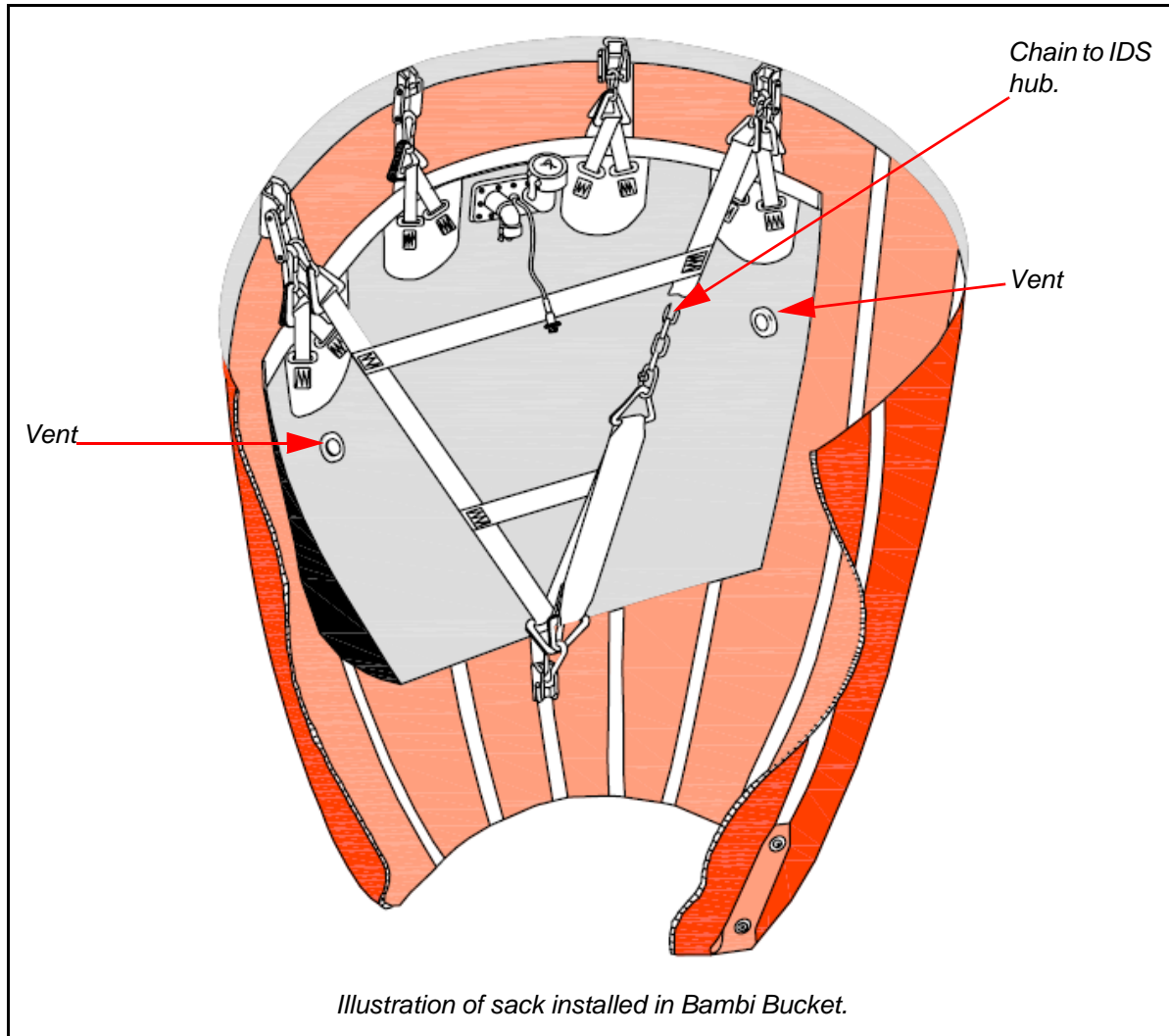

Models 8018, 2044 and 5550

Installation Procedure

Important Note

If the Bambi bucket cinch strap clip is on the ballast side of the bucket, it must be rotated 180 degrees to the opposite side, to allow cinch adjustment once the sack is installed.

To install the sack:

1. Release the bottom end of the ballast side IDS restrainer cable by removing the clevis pin from the restrainer bracket inside the bucket.



2. Tie the restrainer cable out of the way where it will not interfere with bucket operation. It may be reused to restrain the IDS hub if the sack and IDS restrainer strap are later removed.



3. Attach one end of the chain to the 1/4" shackle and attach the shackle to the IDS hub. Determine the length of chain from the table. Insert the quick link into the determined chain length and insert the quick link into the D-ring at the end of the webbing strap and secure.



Chain Length Specifications

Bucket Size	Length of Chain (Quick link to strap, in inches)	Model
8096	3	8018
9011	3	
1012	3	
1214	3	
1518	12	
1821	12	
2024	15	2044
2226	15	
2732	21	
3542	22	
4453	22	
5566	35	5550
680K	25	
6578	33	
7590	32	
HL5000	41	

4. Connect the lower end of the restrainer strap to the restrainer bracket, reinstalling the clevis pin (removed in step 1). Use a new cotter pin to secure the clevis pin to the restrainer bracket.



Connecting the restrainer strap.



The installation should now look like this.

5. Disconnect the bottom end of the IDS restrainer cable, opposite the ballast, by removing the clevis pin from the restrainer bracket. Attach the supplied shackle and length of chain to the IDS restrainer cable and re-connect it to the bracket. If the IDS cable already has a chain fitted, extend it to its longest length.



6. Attach spring clips to the top of sack.



7. Fold up the sack and slide it in between the spokes and into the bucket. For smaller buckets, remove one spoke at the shell end. The sack should be centered on the ballast pouch. The IDS restrainer strap attached, in steps 3 and 4, should pass around the bottom of the sack.



Caution

Do not remove the Bambi bucket's ballast pouch when fitting the sack. This could cause unpredictable flight characteristics.

8. Install the shackles onto the webbing suspension straps at the bucket rim to line up with the spring links on the sack.



9. Straighten out the sack so that it sits straight inside the bucket.

10. Connect the control cable to the waterproof connector on the sack. Ensure that the white waterproofing washer is installed inside the receptacle.

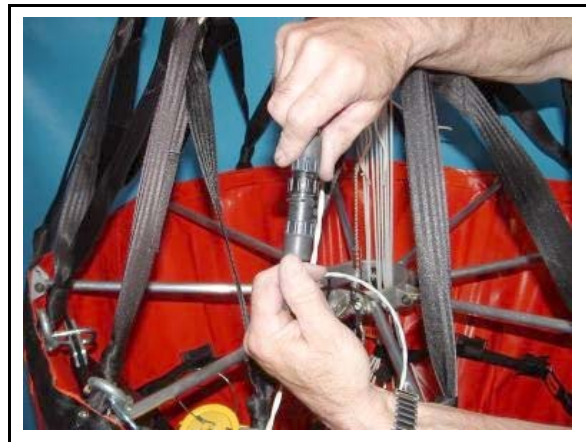

11. Install the breakaway connector in the control cable, near the Bambi control head.



12. Secure the control cable to one of the Bambi suspension cables using the tie wraps provided. The connector may be taped together to prevent premature release.

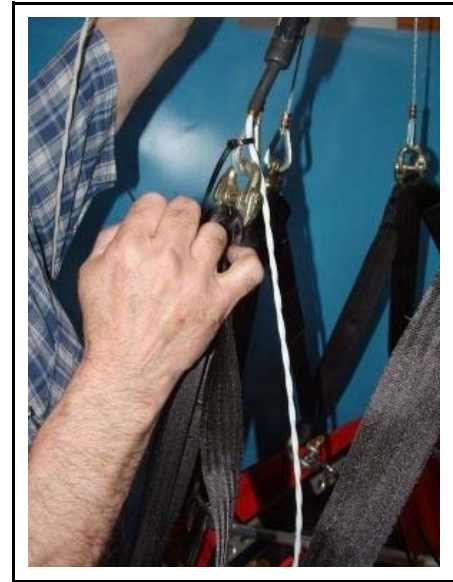

Caution

IDS restrainer cable and strap adjustments are required to keep the IDS hub as flat as possible throughout its vertical range of travel. If improperly adjusted, the IDS hub will not sit level when the bucket is empty.

This is due to the deformation of the Bambi bucket shell, caused by the weight of the Sacksafoam. Improper adjustment may result in fouling of the trip line pulley on the IDS hub (small series) and/or severe damage to the entire IDS (all models).

Model 7698

Installation Procedure

1. Release the bottom end of the ballast side IDS restrainer cable by removing the clevis pin from the restrainer bracket inside the bucket. See picture above for locations.
2. Tie the restrainer cable out of the way so that it will not interfere with bucket operation. It may be reused to restrain the IDS hub, if the sack and IDS restrainer strap are later removed.
3. Adjust the chain connected to the IDS restrainer strap to the length which corresponds to your bucket size. Then connect a 1/4" quick link. Attach the quick link to the IDS hub.

Chain length specifications for this model.

HL7600	45	7698
HL9800	48	

4. Disconnect the four spokes centred over the ballast bars by removing the clevis pins or bolts which connect spokes to the shell brackets.

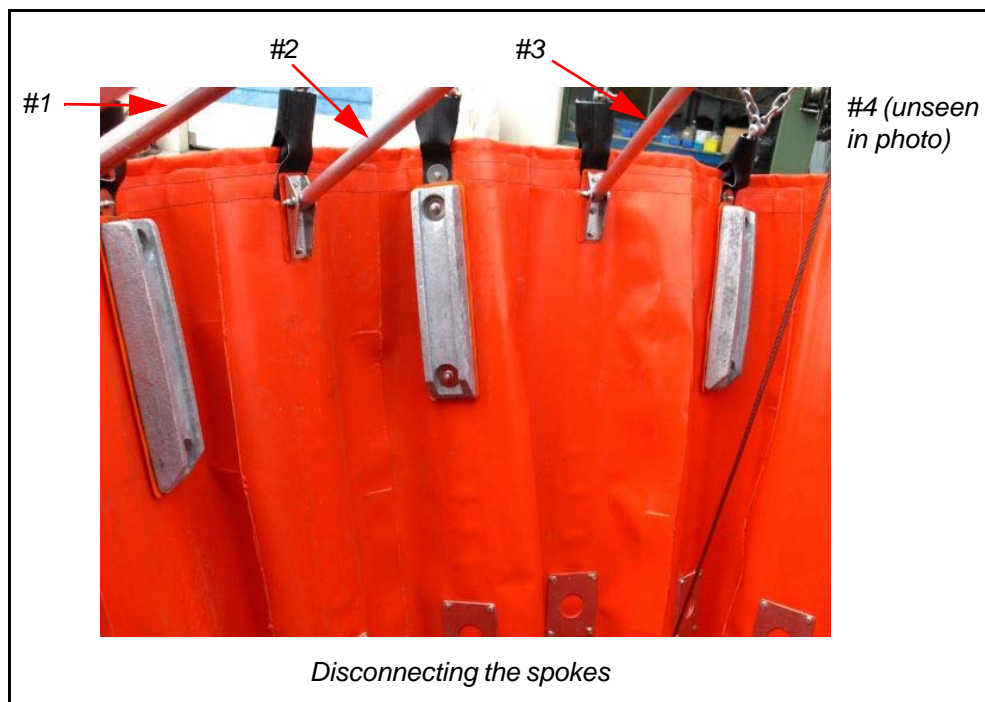

5. With the hardware supplied, attach the suspension hanger and spoke to the shell bracket.



6. Fold up the sack and slide it in between the spokes and into the bucket. The sack should be centered on the ballast pouch. The IDS restrainer strap and sack harness, attached in steps 3 and 4, should pass around the bottom of the sack.
7. Connect the spring links on the sack to the suspension hangers on the bucket.
8. Straighten out the sack so that it sits straight inside the bucket.
9. Connect the control cable to the waterproof connector on the sack.

Caution

Ensure the white waterproofing washer is installed inside the receptacle.

10. Install the breakaway connector in the control cable near the Bambi control head. Secure the control cable to one of the Bambi suspension cables using the tie wraps provided. The connector may be taped together to prevent premature release.

Section 3: Safety

Preflight Safety Check

The Bambi bucket and Sacksafoam I system should receive a preflight inspection in the same manner as a pilot preflights the aircraft before use. To preflight the system, start at the bottom and work up.

1. Are all the attachments connecting the sack to the Bambi bucket firmly secured?
2. Is the wiring connector (close to the sack) tightly secured? Does it have the white waterproofing washer installed inside the receptacle?
3. Is the power cable leading to the sack secured to one of the Bambi bucket suspension lines?
4. Is there a breakaway plug installed in the power cable near the cargo hook? Is it taped together to prevent premature release?
5. Is the control box operating properly? (Cap the outlet port on the sack to avoid dispensing foam when testing the control box.)
6. Are the wires in the helicopter secured to avoid tripping and tangling?
7. Prior to takeoff, ensure that the camlock cap on the foam outlet port is removed.

Refer to the Bambi bucket manual for the preflight check on the Bambi bucket itself.

Section 4: Control Box

Wiring the Control Box

The control box has a 3-amp breaker that protects its electronic components. Be sure to observe correct polarity. The control box will not operate if hooked up with reverse polarity.

The injection pump is protected by the helicopter circuit breaker. The injection pump will work but at a greatly reduced volume if hooked up with reverse polarity.

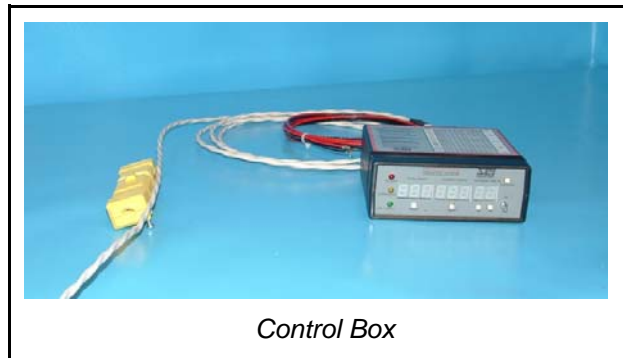

1. Connect power input wires (red is positive, black is negative) to a 28-volt direct current power supply, protected by a 10-amp breaker (20-amp breaker for HL series Sacksafoam only). In this case, 28-volts is the nominal charging voltage on a 24-volt system.
2. Connect the nine pin plug to the socket on the back of the control box (pin 1 is positive, pin 2 is negative).
3. To install the optional remote dispense switch: locate a single pole, single throw switch on the collective. Connect the blue wire from pin 3 to the switch. Connect the opposite pole on the switch to ground (-24 VDC).

Caution

Excessive force or twisting on the wiring connector can damage the contacts.

4. Check that the control box and injection pump operate. Install the camlock cap on the foam outlet port to prevent the dispensing of foam. Set the dispense time switch to five seconds. Turn the on/off switch ON. Momentarily lift the dispense switch. The orange dispensing light should come on and the injection pump should run for five seconds.

Using Long Lines

The supplied control cable (connecting the control box and sack), fits Bambi buckets with standard length suspension lines. The cable is sized to provide 24-volts to the injection pump when 28-volts is supplied to the control box. If the Bambi bucket is suspended from the helicopter with an additional long line, the standard control cable may not be long enough.

If a longer control cable is required, the correct gauge can be determined by the following method (the objective is to provide 24-volts to the injection pump after accounting for the voltage drop along the cable).

Calculating Wire Gauge for Long Lines

The Sacksafoam pump draws the following current:

Small and medium series 4.5-amps

HL Series 9.0-amps

Control cables supplied with the Sacksafoam I unit meet Mil-C-27500 specifications. Individual hook-up wires meet Mil-W-22759/16 specifications. It is recommended that any replacement wire or cable meet these specifications. Extra cable and wire is available from SEI Industries Ltd.

Wire Specifications

With a supply voltage of 28-volts and a requirement of 24-volts at the pump, the voltage can drop four volts.

The current has to flow in both directions, so the wire length used in the calculation will be the distance from the control box to the sack, multiplied by two.

Wire Size (AWG #)	Resistance	
	Ohms/1000 ft	Ohms/1000 m
18	5.74	18.83
16	4.51	14.80
14	2.88	9.45
12	1.82	5.97
10	1.18	3.87

Use this formula, based on Ohms law ($V=IR$).

Voltage drop, $V_d = \text{Amps draw} \times \text{resistance}/1000 \times \text{wire length} \times 2$

Example: A 100 ft. long line with a HL-7600 Bambi bucket and a 12 gauge wire, with a length of 160 ft. from the control box to the sack.

$$V_d = 9 \times \frac{1.82}{1000 \text{ ft}} \times 160 \text{ ft.} \times 2 = 5.24 \text{ volts}$$

Therefore, a 12 gauge wire would be satisfactory. It would produce a slightly low voltage at the pump ($28 - 5.24 = 22.76$ volts), which could be compensated for by adjusted run times shown in Section 5 *Operations: (Variation in Foam Viscosity and Using Non-Standard Voltages)*. Wire specifications can be calculated in feet or meters.

Section 5: Operations

Operating All Models

Filling the Sack

1. If any adjustment of the Bambi bucket cinch strap is required, it should be made prior to the installation and filling of the sack. Adjusting the cinch strap is difficult when the sack is full of foam.

Important Note

The volume of the sack should be reduced 20% for every 10% reduction in Bambi bucket volume.

2. Remove the camlock plug from the fill port.



3. Pour or pump in foam concentrate.

Caution

Overfilling the sack with the Bambi bucket cinched down may cause the dump valve to jam.

4. All air trapped in the sack must be removed, otherwise the Bambi bucket may not sink when dipped in the water. If the sack is lying on the ground, excess air can be removed by opening the vents on each side and pressing down in the centre of the sack. Close the vents tightly after exhausting all of the air.



5. Replace the camlock filler plug.



6. Remove the camlock cap from the foam outlet port. An internal check valve ensures foam is dispensed only while the injection pump is operating.

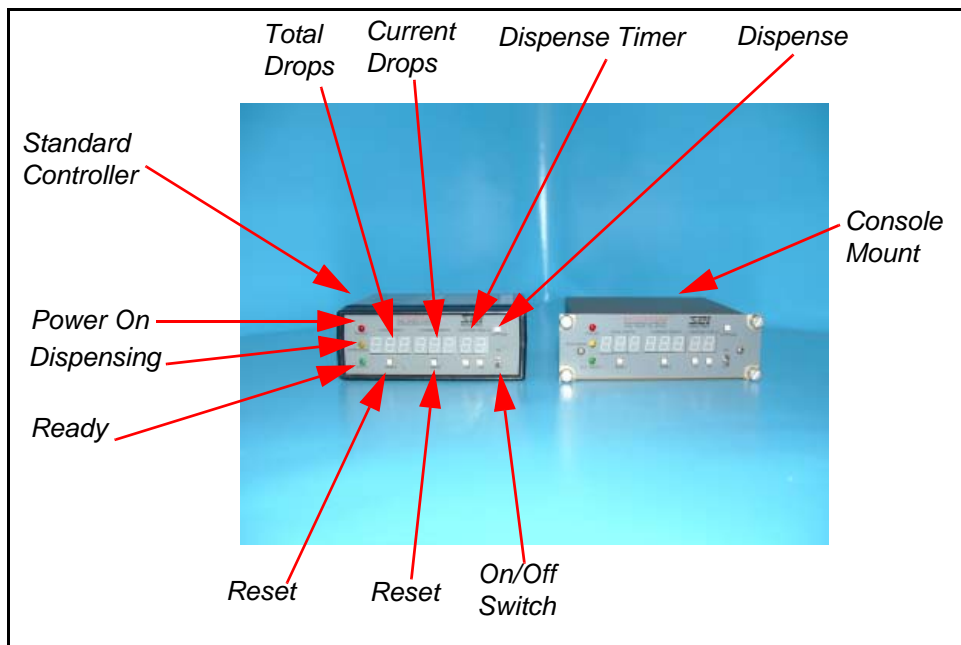

Dispensing Foam

1. Mount the console in a convenient location inside the helicopter.
2. Select the desired concentration and run time from the chart on top of the control box (or the chart supplied loose with the console.)
3. Set desired run times by pressing the small buttons on the digital dispense time switch. See the table of control box functions for switch functions.
4. Turn the control box on/off switch to ON.
5. When the bucket is full and lifted clear of the water, momentarily turn ON the dispense switch to dispense foam.
6. The timer can be reset at any time and the inject cycle stopped by turning the on/off switch OFF, then back ON.

Important Note

For the non-dash mount, the chart on the control box shows the minimum foam concentration available at the indicated run time.

For the dash mount, use the supplied chart and place where operator wants or refer to manual.

Control Box Functions

Item	Function
On/off switch	Toggle up to turn ON. Toggle down to turn off and reset.
Dispense switch	Press/push button to begin dispensing foam.
Dispense time switch	Push buttons to set run time of foam injection pump.
Current drops counter	Both counters increment every time dispense switch is pressed up (on). Current drops counter should be reset when Sacksafoam is refilled. Zero counter by pressing reset button.
Total drops counter	Both counters increment every time dispense switch is pressed up (on). Total drops counter can be used to count the total number of drops per day or shift. Zero counter by pressing reset button.
Red power light	Red light is on when power is on.
Orange dispense light	Orange light is on when unit is dispensing foam.
Green mix ready light	Green light is on when unit is ready for next dispense cycle or mixer (if installed) is running. The green light (and mixer; if installed) will go off when the Bambi bucket is dumped if green wire is hooked up to Bambi dump circuit.

If the Bambi bucket is cinched down, the foam concentration in the bucket will be higher than indicated on the mixing chart on the top of the box.

In this case, the increased concentration is due to a smaller volume of water in the Bambi caused by the displacement of the full sack of foam. The change in concentration is relatively small. For the smallest Bambi bucket used, with its appropriate sack, the concentration will increase about 19% over the indicated concentration; i.e. from 0.5% to 0.6%. For the largest Bambi bucket used, with its appropriate sack, the increase will be about 14% over the indicated concentration; i.e. from 0.5% to 0.57%.

The first pump run will result in a lower concentration of foam as the pump has to fill the discharge pipe. Supplied voltage and the brand of foam will also effect run time required to achieve the desired concentration. See Section 2 *Installation Procedures* and Section 5 *Operations* for more information.

Variation in Foam Viscosity

The run times shown on the control box are calculated using a foam concentrate of average viscosity, such as Firefoam 103. Different brands of foam may require variations in run times to obtain the same percentage dilution.

Brand of Foam	Change in Run Time
Firefoam 103	No change
Forexpan	- 17%
Phos Chek	+ 16%
Silvex	- 20%

Most of these changes are relatively small and, for practical purposes, can be disregarded, particularly at low concentrations and short run times.

Example: For a concentration of 0.5% in a model 9011 Bambi bucket, the chart on the top of the control box shows a run time of 15 seconds. If you are using Silvex, the run time will be 15 seconds minus 20%. The equation for this is $15 - 3 = 12$ seconds.

Note: Most of these changes are relatively small and, for practical purposes, can be disregarded, particularly at low concentrations and short run times.

Using Non-Standard Voltages

If it is not possible to obtain 28-volts at the control box when using the supplied wire, or 24-volts at the injection pump when using a long line, adjust the run times as shown in the table below.

Voltage Variation (volts)	Change in Run Time (%)
+1V	-2%
+2V	-5%
Standard	No change
-1V	+3%
-2V	+7%
-3V	+12%
-4V	+19%

Note: Most of these changes are relatively small and, for practical purposes, can be disregarded, particularly at low concentrations and short run times.

Removing the Sack from the Bucket

1. Reverse installation sequence.
2. If there is any appreciable amount of foam left in the sack, it should be pumped out until the pump runs dry. At this point the sack can be easily removed from the bucket. The remaining foam (approximately four litres with the 8018 sack) can be removed through the drain port.

3. The sack should be flushed with fresh water and pumped out. This will also clean the pump. Drain any residual water through the drain port.

4. Clean off the outside of the sack to remove any foam residue.

Important Note

Proper cleaning of the sack prior to storage will increase the life span of the unit.

Section 6: Troubleshooting

Troubleshooting Chart

Problem	Possible Cause	Solution
Pump fails to operate	Blown breaker Bad connections	Check helicopter breaker and breaker on back of control box. Using a multimeter, check that current is reaching control box and sack. Check contacts and waterproof connector.
Incorrect foam concentration	Pump hooked up backwards	Check pump output by pumping into a bucket. Reverse connections to pump and try again. Select connection that gives highest output.
Bambi bucket valve not working	Sack fouling valve IDS hub tipping and fouling trip line	Reduce amount of foam in sack until it clears valve. Adjust IDS restrainers so that hub sits level.

Section 7: Maintenance

Maintenance Procedures

The Sacksafoam I unit requires no maintenance other than cleaning. Daily, after use, and prior to storage, the sack should be flushed out with clean water. Clean off the outside of the sack to remove any residual foam.

Important Note

Proper cleaning of the sack prior to storage will increase the life span of the unit.

Flushing Procedure

1. Insert one dip tube into a container of clean water.
2. Place the breakaway hose into a bucket and operate the Sacksafoam controller until the water runs clean.
3. Repeat step #2 for the other dip tube. Drain any remaining water from the piping and pump by alternately holding the dip tubes upside-down and operating the Sacksafoam controller.
4. Foam or water in the Sacksafoam case can be drained by removing the drain cap and tipping the unit. Wipe out the case with a damp cloth.
5. Remove the drip tube to drain any residual foam.

Caution

Residual foam will form a waxy substance that can prevent proper operation of the Sacksafoam.

Section 8: Specifications

Sacksafoam Specifications

Sacksafoam Models

(To fit inside the corresponding model of Bambi buckets)

Sack Model Number	Bambi Bucket Model Number	Sack Volume	Current draw @ 28VDC
8018	8096 - 1821	10 Imp. Gallons 12 U.S. Gallons 45 Litres	5 AMPS
2044	2024 - 4453	25 Imp. Gallons 30 U.S. Gallons 114 Litres	5 AMPS
5550	5566 – HL5000	60 Imp. Gallons 72 U.S. Gallons 272 Litres	5 AMPS
7698	HL7600 – HL9800	110 Imp. Gallons 132 U.S. Gallons 500 Litres	10 AMPS

Control Box Specifications

(Subject to change without notice)

Standard control box, Model 302		Weight 20 oz. (550 grams)
Width	5 3/8 inches (136 mm)	
Height	2 1/8 inches (54 mm)	
Length	6 1/8 inches (156 mm)	
In-dash control box, Model 402		Weight 20 oz. (550 grams)
Faceplate		Box
Width	5 3/4 inches (146 mm)	Width 5 inches (127 mm)
Height	1 7/8 inches (48 mm)	Height 1 7/8 inches (48 mm)
		Depth 6 7/8 inches (175 mm)

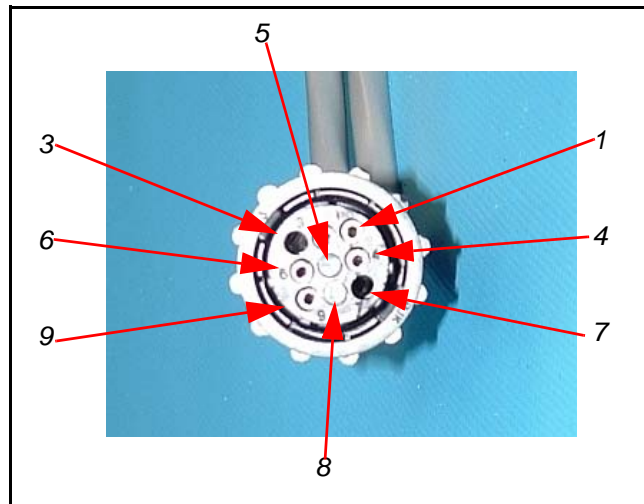
Control Box 9 Pin Connector Configuration

Pin	Description	Wire Color
1	+ 24 VDC supply	red
2	- 24 VDC supply	black
3	+ 24 VDC to remote dispense switch (option)	blue
4	+24 VDC to foam dispense pump	white
5	plugged	
6	- 24 VDC to foam dispense pump	white with blue tracer
7	+ 24 VDC 0.5 AMPS to mixer solenoid (option)	yellow
8	plugged	
9	+ 24 VDC from Bambi dump button	green

Section 9: Sacksafoam Parts Lists

Models 8018, 2044 and 5550

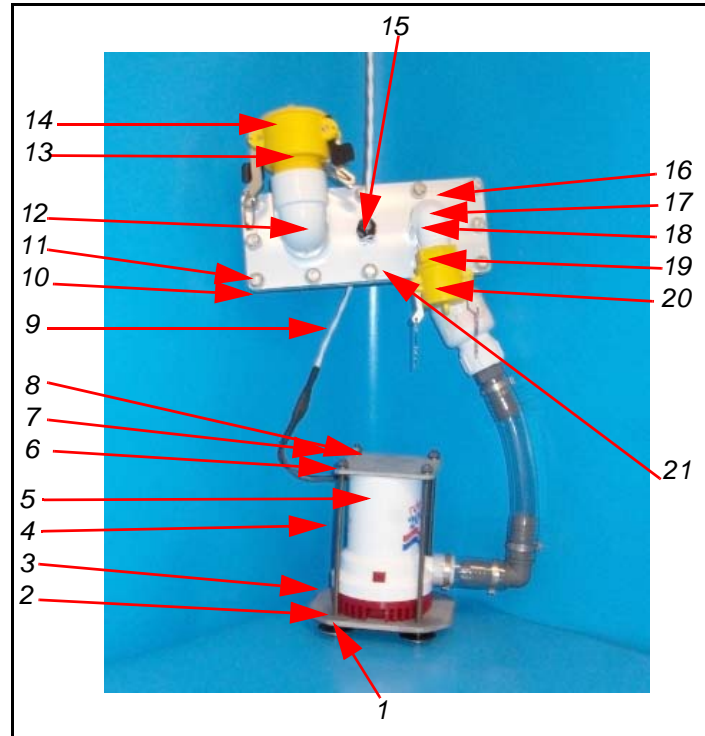
Internal Pump Assembly

ITEM #	PART #	DESCRIPTION	QTY.
1	FNSC0204	Nut nylock S/S 1/4" x 20	4
2	FWS0604	Washer fender 1/4" X 1 1/2"	4
3	SF106	Plate bottom sacksafoam pump	1
4	SF107	Rods mounting sacksafoam pump	4
5	SF002	Pump 24 volt Rule	1
6	FNSC0204	Nut nylock S/S 1/4" X 20	4
7	FNFC0104	Nut hex S/S 1/4 - 20	8
8	SF105	Plate top sacksafoam pump	1
9	SF517	Wire harness bladder	1
10	FWN0305	Washer nylon 5/16"	12
11	FBSC0508	Bolt hex head S/S 5/16 - 18 X 1"	12
12	PLP026	Elbow street 90 deg. 1 1/2" MNPT x FNPT	1
13	PLN251	Coupler 1 1/2" MNPT X 1 1/2" F camlock nylglass	1
14	PLN151	Dust plug 1 1/2" camlock nylglass	1
15	PLP104	Strain relief 3/8 MNPT	1
16	SF101	Flange outer sacksafoam 1	1
17	GAS003	O-ring Buna 1 1/4" id 103	1
18	PLP025	Elbow street 90 deg. 1"	1
19	PLN352	Adapter 1" FNPT X 1" M Camlock	1
20	PLN202	Dust cap 1" camlock	1
21	SF100	Flange Inner Sacksafoam I	1

Internal Pump Assembly (Back Side)

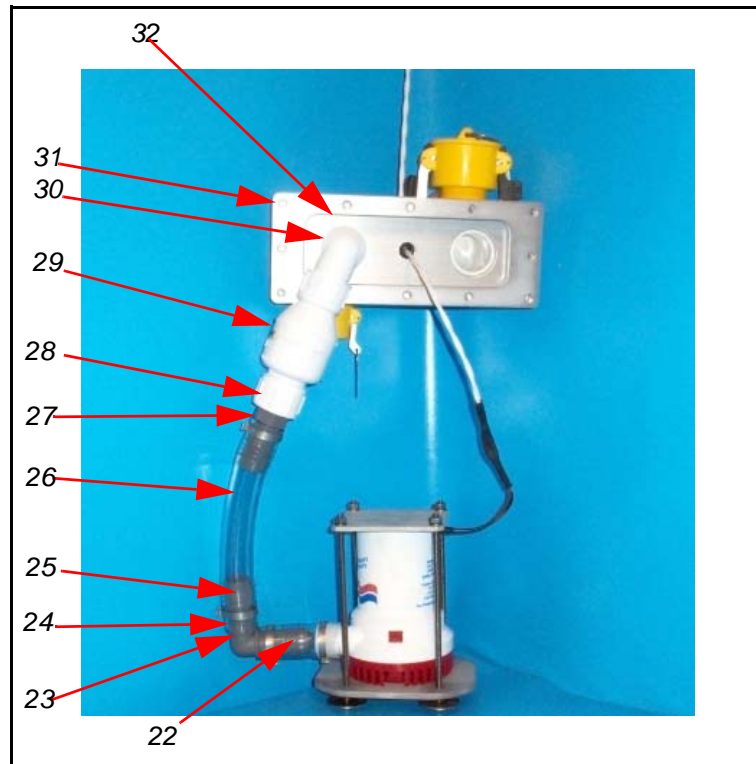

ITEM #	PART #	DESCRIPTION	QTY.
22	PLT004	Hose clear PVC 1" X 3"	1
23	PP400	Oetiker clamp 1 ear 1 7/16"	4
24	PLP050	Elbow 90deg. PVC 1" insert X 1" insert	1
25	PLT004	Hose clear PVC 1" X 8 1/2"	1
26	PLP015	Adapter PVC 1 MNPT X 1" insert nyglass	1
27	SF110	Metering orifice 3/16 model 8018 10 gallon	1
28	SF111	Metering orifice 5/16 model 2044 25 gallon	1
29	PLV003	Valve check 1 FNPT X 1/2 PSI	1
30	PLP025	Elbow street 90 deg. 1"	1
31	SF100	Flange inner Sacksafoam 1	1
32	PLP001	Nipple PVC sch. 80 1"	1

External Parts

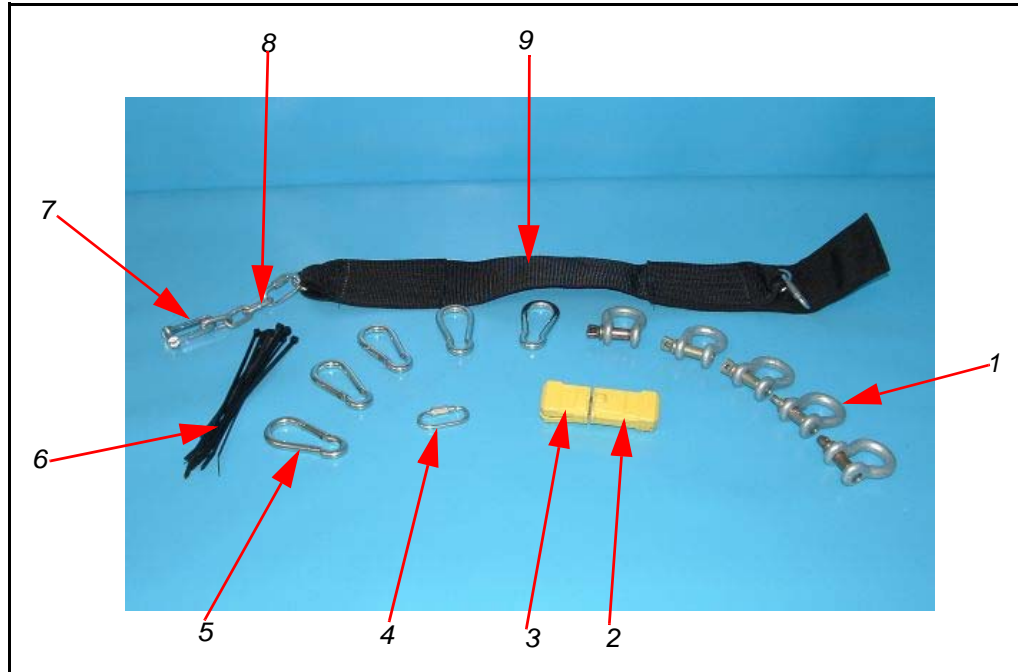

ITEM #	PART #	DESCRIPTION	QTY.
1	FTAG007	Shackle anchor 3/8" pin galvanized	5 or 7
2	ECON025	Plug male 2 prong polarized	1
3	ECON026	Receptacle female 2 prong polarized	1
4	PP203	Quick link plated 1/4"	3
5	PP211	Hook spring plated 5/16"	5 or 7
6	PP001	Tiewrap black 3/16 X 7"	10
7	FTMS001	Shackle S/S long 6MM pin	1
8	RMCG001	Chain 3/16" galvanized	1 FT.
9	SF525	Restrainer strap assembly	1

Complete Unit

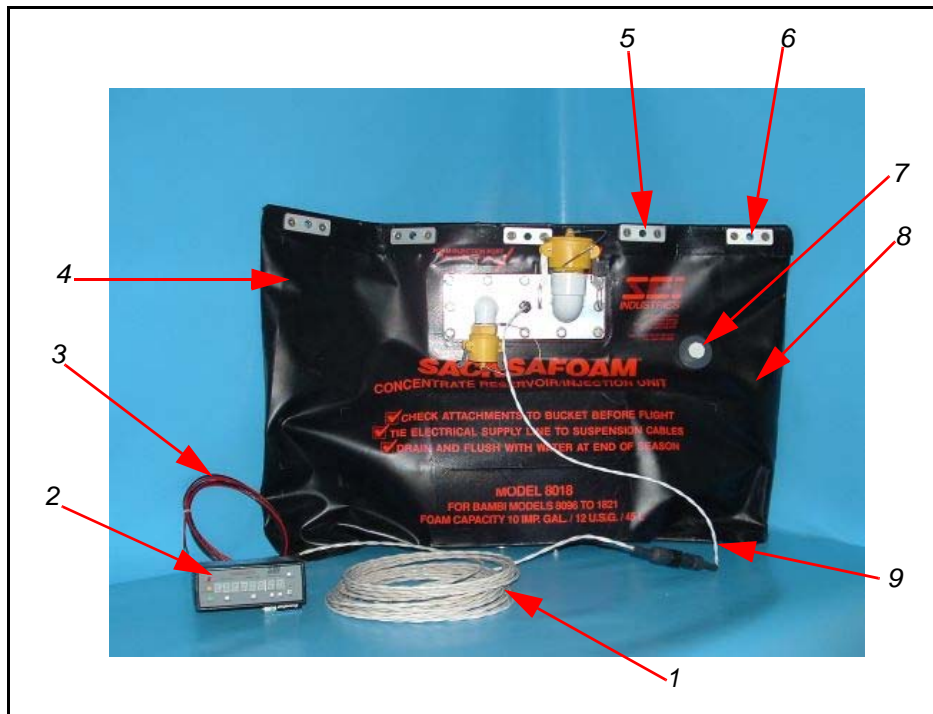

ITEM #	PART #	DESCRIPTION	QTY.
1	SF515	Wire harness power/control SF1	1
2	SFF003	Sacksafoam control box regular #502	1
2	SFF004	Sacksafoam control box panel mount d-zus #602	1
3	-----	Power in part of Item #1 SF515	0
4	SFS010	Sack 10 gallon model 8018	1
4	SFS020	Sack 20 gallon model 2044	1
4	SFS025	Sack 25 gallon model 5055	1
4	SFS060	Sack 60 gallon model 7698	1
5	SFS060R	Reinforcement plate set	1
6	FBSC030404	Bolt S/S flat head Phillips ¼ - 20 X ½"	Ea
7	PLP102	Plug pipe PVC ½" MNPT	1
8	PLP060	Bulkhead fitting PVC ½" FNPT	1
9	SF517	Wire harness bladder	1

Model 7698 Parts List

External Parts

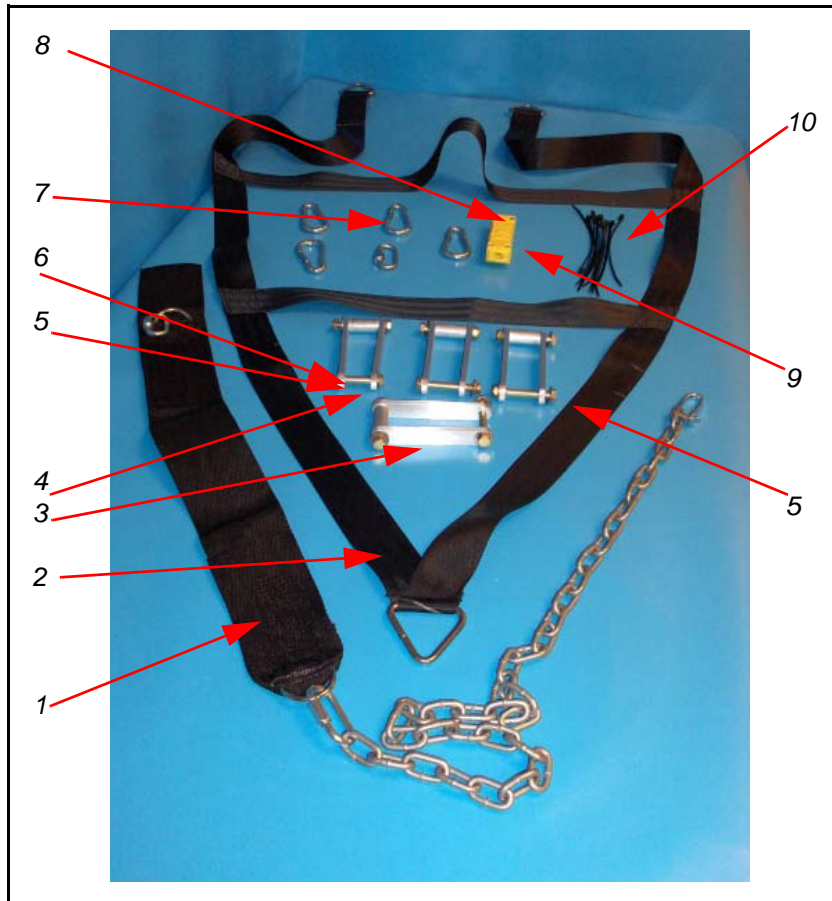

ITEM #	PART #	DESCRIPTION	QTY.
1	SF525	Restrainer strap assembly	1
2	SF527	Harness bladder 110 gal. model 7698	1
3	SF529	Hanger set SF 7698 bladder	1
4	FBCF010522	Bolt plated 5/16 – 24 X 2 11/32 hex head	1
5	FWS0205	Washer flat S/S 5/16 thin	1
6	FNAN364-524	Nut nylock jam 5/16 – 24	1
7	PP211	Hook spring plated 5/16	1
8	ECON025	Plug male 2 prong polarized	1
9	ECON026	Receptacle female 2 prong polarized	1
10	PP001	Tiewrap black 3/16 X 7	1

Internal Pump Assembly

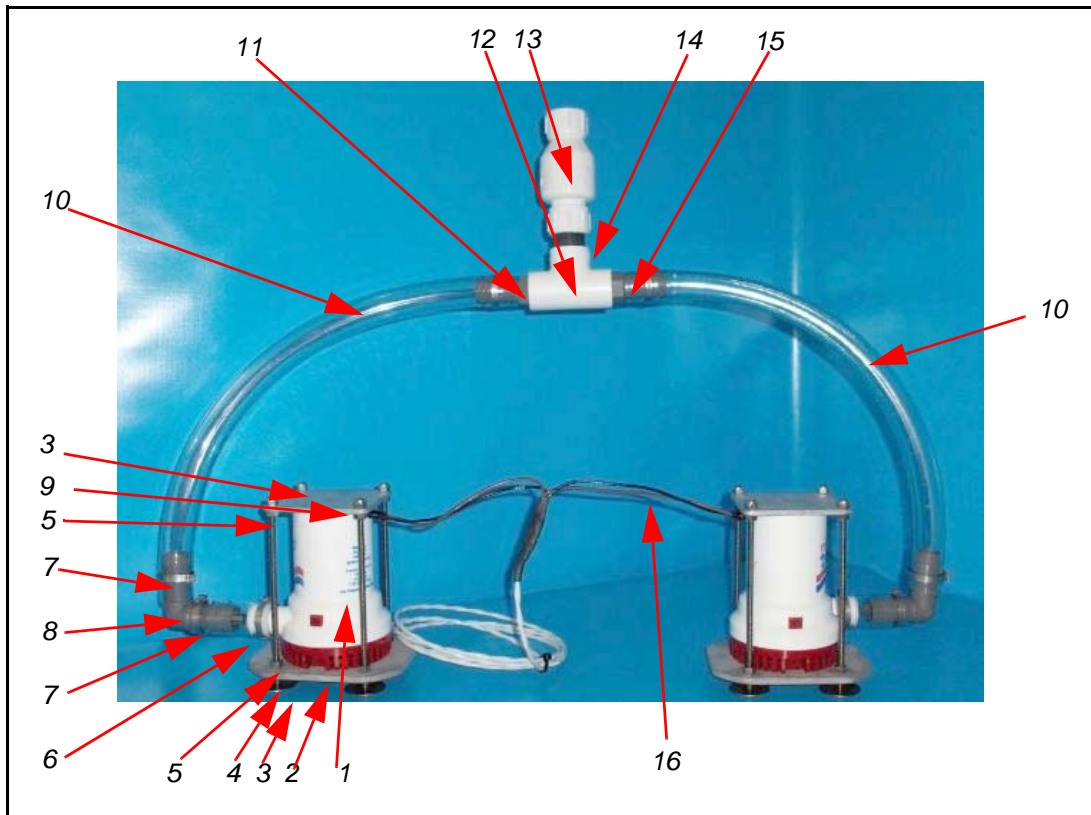

ITEM #	PART #	DESCRIPTION	QTY.
1	SF002	Pump 24 volt Rule	2
2	SF106	Plate bottom sacksafoam 1 pump	2
3	FNSC0204	Nut nylock S/S ¼ X 20	16
4	FWS0604	Washer fender ¼" X 1 ½"	8
5	FNFC0104	Nut hex S/S ¼ - 20	16
6	PLT004	Hose clear PVC 1" X 3"	2
7	PP400	Oetiker clamp 1 ear 1 7/16"	8
8	PLP050	Elbow 90 deg. PVC 1" insert X 1" insert	2
9	SF105	Plate top sacksafoam 1 pump	2
10	PLT004	Hose clear PVC 1" X 36"	2
11	PLP015	Adapter PVC 1" MNPT X 1" insert	2
12	PLP1009	Tee PVC sch. 80 1 ½" FNPT	1
13	PLV00310	Valve check 1 ½" FNPT X ½ PSI	1
14	PLP006	Nipple PVC sch. 80 1 ½" close	1
15	PLP129	Bushing PVC 1 ½" MNPT X 1" FNPT	2
16	SF517	Wire harness Bladder	1

Fill and Discharge Flange Assembly

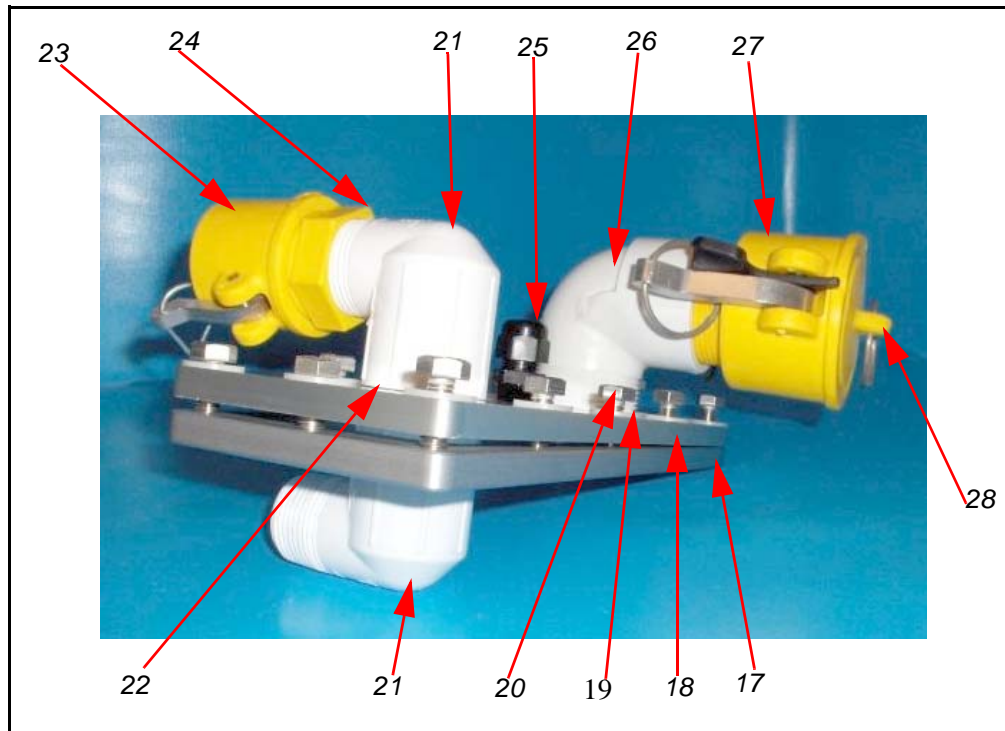

ITEM #	PART #	DESCRIPTION	QTY.
17	SF100	Flange inner Sacksafoam 1	1
18	SF102	Flange outer Sacksafoam 1 HL	1
19	FWN0305	Washer Nylon 5/16"	12
20	FBSC0508	Bolt Hex Head S?S 5/16 – 18 X 1"	12
21	PLP026	Elbow street 90 deg. PVC 1 ½" MNPT X FNPT	2
22	GAS004	O-ring Buna 1 7/8 ID	1
23	PLN204	Dust cap 1 ½" camlock nyglass	1
24	PLN251	Coupler 1 ½" MNPT X 1 ½" M camlock Nyglass	1
25	PLP104	Strain relief 3/8" MNPT	1
26	PLP027	Elbow Street 90 deg. PVC 2" MNPT X 2" FNPT	1
27	PLN253	Coupler 2" MNPT X 2" F camlock nyglass	1
28	PLN205	Dust plug 2"camlock nyglass	1
28	SF102	Flange outer sacksafoam 1 HL	1

Section 10: Warranty

- a) Warranty is limited to repairing or replacing, at the company's sole discretion, any product approved to be defective.
- b) The company's products are not guaranteed for any specific length of time or measure of service, but are warranted only to be free from defects in workmanship and material for a period of one year to the original purchaser.
- c) To the extent allowable under applicable law, the company's liability for consequential, incidental and environmental damages is expressly disclaimed. **The company's liability in all events is limited to and shall not exceed, the purchase price paid.**
- d) This warranty is granted to the original purchaser and does not extend to a subsequent purchaser or assignee.
- e) The company must receive notification in writing of any claims of warranty from the original purchaser which must give details of the claimed defect in the product.
- f) Where the original purchaser is claiming under warranty, the product must be returned to the company for inspection with all transportation and duty charges prepaid.
- g) The warranty does not extend to any product that has been accidentally damaged, abraded, altered, punctured, abused, misused or used for a purpose which has not been approved by the company.
- h) This warranty does not apply to any accessories used with the product such as pumps, filters, hoses, etc., that are not supplied by the company, and any warranty on such accessories must be requested from the manufacturer or dealer of the accessories.
- i) In the event the original purchaser does not give notice of a warranty claim within one year of the original purchase of the product, it is understood that the purchaser has waived the claim for warranty and the purchaser and/or any subsequent purchaser must accept the condition of the product as it may be, without warranty.
- j) Any technical information supplied by the company regarding the product is not a condition of warranty but rather is information provided by the company to the best of its knowledge.
- k) There are no implied warranties nor is there any warranty that can be assumed from any representation of any person, except the company itself.

Exclusions

This warranty is void if the product is not assembled, used and/or maintained in accordance with the operator's manual supplied by SEI.